

Wireless Digital Flat Panel Detector

Mars1417V

User Manual

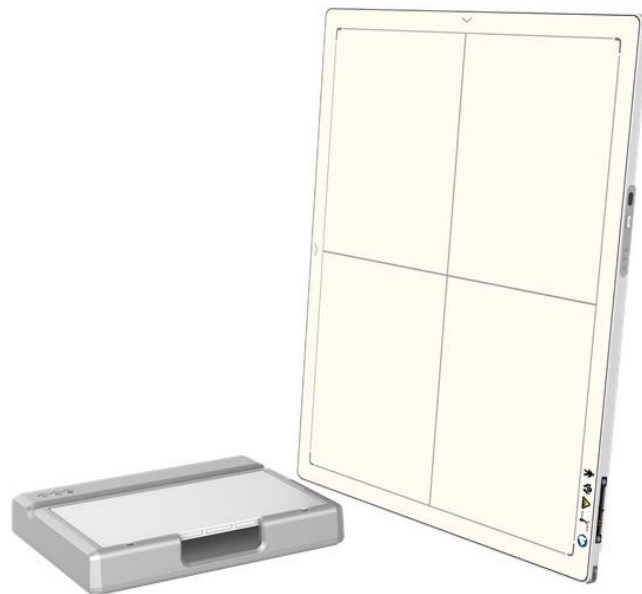

Document Version: A1

Document ID: 085-201-10

Release Date: 2019-08-06



Before operating, please read this user manual and pay attention to all safety precautions.

Please ensure that this user's manual is properly maintained so that it can be accessed at any time (reserve).

Please use it correctly on the basis of full understanding of the content.



Congratulations on your purchase of Mars1417V (configuration: Mars1417V3) Digital Flat Panel. We strive to not only make the world-class products that deliver the best value to our users but also offer the highest quality of service and customer care. Please take time to read user manual to utilize the product effectively. We hope you enjoy the experience with Mars1417V (configuration: Mars1417V3).

If you have any questions or suggestions, please feel free to contact us.

Service Office

Tel: +86 21 50720560

Fax: +86 21 50720561

**Location: Rm. NO.33 Xinggang Road, Taicang Port Economic and
Technological Development Zone, Jiangsu, China, PC: 215434**

Notes on usage and management of the equipment

1. Read all of the instructions in user manual before operation. Give particular attention to all safety precautions.
2. Only a physician or a legally certified operator could use the product.
3. The product should be maintained in a safe and operable condition by maintenance personnel.
4. Use computers and image display monitors complying with IEC 60601-1 or IEC 60950-1. For details, consult our sales representative or local dealer.
5. Use dedicated cables. Do not use any cables other than those supplied with the product.
6. Request your sales representative or local dealer to install the product

Caring for your environment



This symbol indicates that this product is not to be disposed of with your residential or commercial waste

Recycling Equipment

Please do not dispose of this product with your residential or commercial waste. Improper handling of this type of waste could have a negative impact on health and on environment. Some countries or regions, such as the European Union, have set up systems to collect and recycle electrical or electronic waste. Contact your local authorities for information about dropping off waste product for recycling. If collection systems are not available, call Customer Service for assistance.

Disclaimer

1. Our company shall not be liable to the purchaser of this product or third parties for any damage, loss, or injury incurred by purchaser or third parties as a result of fire, earthquake, any accident, misuse or abuse of the product.
2. Our company shall not be liable to any damage, loss, or injury arising from unauthorized modifications, repairs, or alterations to the product or failure to strictly comply with operating and maintenance instructions.
3. Our company shall not be liable for any damage or loss arising from the use of any options or consumable products other than those dedicated as Original products by our company.
4. It is the responsibilities of user or physician to maintain the privacy of image data and provide medical care services. Our company shall not be responsible for the legality of image processing, reading and storage nor shall it be responsible for loss of image data for any reason.
5. Information regarding specification, compositions, and appearance of this product is subject to change without prior notice.

Copyright







1. All rights reserved
2. No part of this publication may be reproduced in any form or by any means without the written permission of our company. The information contained herein is designed only for use with Mars1417V.

Trademarks

The company name and logo are registered trademarks of our company.



Symbols and Conventions









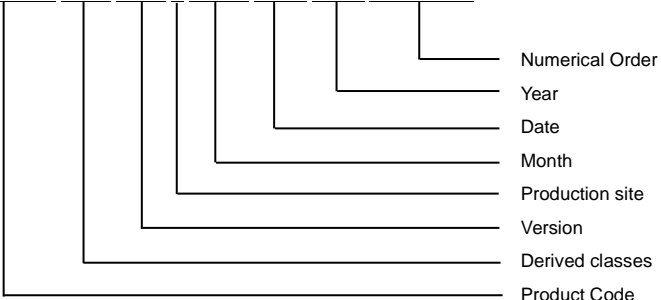

The following symbols and conventions are used in user manual.







 WARNING	This symbol is used to identify conditions under which improper use of the product may cause death or serious personal injury.
 CAUTION	This notice is used to identify conditions under which improper use of the product may cause minor personal injury.
CAUTION	This notice is used to identify conditions under which improper use of the product may cause property damage.
 Prohibited	This is used to indicate a prohibited operation.
	This is used to indicate an action that must be performed.
 Important	This is used to indicate important operations and restrictions.
 Information	This is used to indicate operations for reference and complementary information.

Labels and markings on the equipment

The contents of the labels and markings on Mars1417V (configuration: Mars1417V3) product are indicated below:

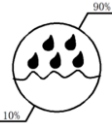
ICON	MEANING
	Caution: please refer to the instructions in user manual.
	This symbol indicates that the product has passed CE certification and followed by CE number.

	<p>This symbol is used to identify the manufacture series number which is after, below or adjacent to the symbol. The series number of our products is usually made of nineteen digits as shown below:</p> <p><u>A1A2A3A4 B1B2 C1C2 L M1M2 D1D2 Y1Y2 X1X2X3X4</u></p> 
	<p>This symbol indicates the name and address of manufacturer.</p>
	<p>This symbol indicates the name and address of our company authorized representative in the European region.</p>
	<p>This symbol is used to indicate consultation of the user guide for general information.</p>
	<p>Safety Signs: please refer to user manual for safety instructions</p>
	<p>Safety Signs: Dangerous Voltage</p>
	<p>Handled with care</p>
	<p>This symbol indicates operational temperature limits.</p>
	<p>This symbol indicates storage temperature limits.</p>
	<p>This symbol indicates the product radiates wireless signal.</p>
<p>FCC</p>	<p>This symbol indicates the product has passed FCC certification.</p>

	Package symbol, fragile.
	Package symbol, keep away from sunlight.
	Package symbol, keep dry.
	This symbol indicates the humidity limits.
	Keep the product up right
	Do not roll the transportation package.
	This symbol indicates stacking limit number.
	Type-B applied part
IP	IPX1 for working surface only

Contents

1. SAFETY	11
1.1. Safety precautions.....	11
1.2. Notes for Using.....	16
2. GENERAL DESCRIPTION.....	19
2.1. Scope	19
2.2. Model.....	19
2.3. Characteristic	20
2.4. Intended use/ essential performance/ application specification.....	20
2.4.1. Intended use	20
2.5. Essential performance	20
2.5.1. Application specification	20
2.6. The relative position between patient and detector	21
2.7. Product Components	21
2.8. Components Description.....	23
2.8.1. Detector.....	23
2.8.2. Battery.....	24
2.8.3. Battery Charger.....	24
2.9. Product Specification.....	26
2.9.1. Detector.....	26
2.9.2. Battery.....	27
2.9.3. Battery Charger.....	28
2.9.4. Power supply.....	28
2.9.5. AP Router	28
2.9.6. Wireless Communication.....	29
2.9.7. Recommended Application Condition.....	29
2.9.8. Mechanical Outlines	29

2.9.9.	Use Environment	30
2.10.	IT network.....	30
2.10.1.	Purpose for IT-network.....	30
2.10.2.	Required characteristics	30
2.10.3.	Required configuration	30
2.10.4.	Technical specifications.....	30
2.10.5.	Intended information flow	31
2.10.6.	Hazardous situations resulting from failure of the IT-network.....	31
2.10.7.	Warning	31
2.10.8.	Changes to the IT-network include	31
3.	INSTALLATION.....	33
3.1.	Panel Installation.....	33
3.1.1.	Attach Battery Pack	33
3.1.2.	Attach DC Power	33
3.1.3.	Booting Up.....	34
3.1.4.	Button function	36
3.2.	Battery Charger Installation	36
3.3.	Battery lock and activation	37
3.4.	Software Installation.....	38
3.5.	Panel Infrastructure	38
3.5.1.	Wireless Client Mode	38
3.5.2.	Wireless AP Mode	42
4.	OPERATION	48
4.1.	Main Operation	48
4.1.1.	Software Mode.....	48
4.1.2.	Inner2 Mode.....	50
4.1.3.	Freesync Mode.....	52
4.2.	Connection Build	53
4.3.	Panel Configuration.....	54

4.4. Correction and Calibration Template Generation	55
4.4.1. Pre-offset Template Generation	55
4.4.2. Gain Calibration Template Generation	57
4.4.3. Defect Correction Template Generation	58
4.5. Image Check and upload	60
4.5.1. Local Image Check	60
4.5.2. Panel Image Upload	61
4.6. Defect Template Check and Modification	61
4.6.1. Defect Template Check.....	62
4.6.2. Defect Template Modification	63
4.7. Correction and Calibration Management.....	64
4.7.1. Correction and Calibration template synchronization	64
4.7.2. Correction and Calibration management	65
4.8. Firmware Update	66
4.8.1. MCU Update.....	66
4.8.2. FPGA Update.....	69
4.8.3. ARM Update.....	71
4.8.4. ALL FIRMWARE Update.....	73
4.9. Short cut	73
4.10. Software.....	74
4.10.1. Main GUI.....	74
4.10.2. Message Box.....	75
4.10.3. Configuration GUI.....	76
4.11. List of the HAZARDOUS SITUATIONS resulting from a failure of the IT- NETWORK	79
5. REGULATORY INFORMATION	81
5.1. Medical equipment safety standards	81
5.2. The compliance for each EMISSIONS and IMMUNITY standard or test specified by IEC60601-1-2 standard	82



5.3. Radio Frequency Compliance Information.....	85
5.3.1. FCC Compliance.....	85
5.4. Battery Safety Standards.....	86
6. TROUBLE SHOOTING	88
7. SERVICE INFORMATION.....	90
7.1. Product Lifetime.....	90
7.2. Regular Inspection and Maintenance.....	90
7.3. Repair.....	90
7.4. Replacement Parts Support.....	90





1. SAFETY	11
1.1. Safety precautions	11
1.2. Notes for Using	16

1. Safety

1.1. Safety precautions



Follow these safeguards and properly use the product to prevent injury and damage to it.

WARNING	
<p>Installation and environment of use</p>  <p>Prohibited</p>	<ul style="list-style-type: none"> ● Do not use or store the product near flammable chemicals such as alcohol, thinner, benzene, etc. If chemicals are spilled or evaporated, it may result in fire or electric shock through contact with electric parts inside the product. Also, some disinfectants are flammable. Be sure to take care when using them. ● Do not connect the equipment with anything other than specified. Doing so may result in fire or electric shock. ● All patients with active implantable medical devices should be kept away from the product.
<p>Power supply</p>  <p>Prohibited</p>	<ul style="list-style-type: none"> ● Do not operate the product with power supply other than the one indicated on the rating label. Otherwise, it may result in fire or electric shock. ● Do not handle the product with wet hands. You may experience electric shock that could result in death or serious injury. ● Do not place heavy object on cables and cords. Do not pull, bend, bundle, or step on them to prevent their sheath from being damaged, and do not alter them neither. Doing so may damage the cords which could result in fire or electric shock. ● Do not supply power to more than one piece of product with the same AC outlet. Doing so may result in fire or electric shock. ● Do not turn on system power when condensation has formed on the equipment. Doing so may result in fire or electric shock. ● Do not connect multiple portable socket-outlets or extension cords to the system. Doing so may result in fire or electric shock. ● To avoid the risk of electric shock, this product must only be connected to power supply with protective earth. Not doing so may result in fire or electric shock. ● Do not connect the adapter cord when connect the panel to patient.

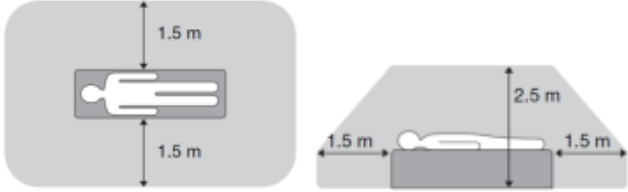
	<ul style="list-style-type: none"> ● Securely plug the power cord into the AC outlet. If contact failure occurs, or if metal objects come into contact with exposed metal prongs of the plug, fire or electric shock may result. ● Be sure to turn off the power before connecting or disconnecting the cords. Otherwise, you may get an electric shock that could result in death or serious injury. ● Be sure to hold the plug or connector to disconnect the cord. If you pull the cord, the core wire may be damaged, resulting in fire or electric shock.
WARNING	
<p>Handling</p>  <p>Prohibited</p>	<ul style="list-style-type: none"> ● Never disassemble or modify the product. No modification is allowed. Doing so may result in fire or electric shock. Also, since the product incorporates parts that may cause electric shock as well as other hazardous parts, touching them may cause death or serious injury. ● Do not place anything on top of the product. The object may fall and cause an injury. Also, if metal objects such as needles or clips fall into the product, or if liquid is spilled, it may result in fire or electric shock. ● Do not hit or drop the product. The product may be damaged if it receives a strong jolt, which may result in fire or electric shock if it is used without being repaired. ● Do not put the product and pointed objects together. The product may be damaged. If so, it should be used in bucky.
	<ul style="list-style-type: none"> ● Have the patient take a fixed posture and do not let the patient touch parts unnecessarily. If the patient touches connectors or switches, it may result in electric shock or malfunction.
<p>When a problem occurs</p> 	<ul style="list-style-type: none"> ● Should any of the following occurs, immediately unplug the power cord of adaptor or battery, and contact your sales representative or local dealer: When there is smoke, an odd smell or abnormal sound. When liquid has been spilled into the equipment or a metal object has entered through an opening. When the product has been dropped and damaged.
<p>Maintenance and inspection</p>  <p>Prohibited</p>	<ul style="list-style-type: none"> ● Please turn off power of the product and unplug power cord of adapter before cleaning. ● Never use alcohol, ether and other flammable cleaning agent for safety. Never use methanol, benzene and acid because they would corrode the equipment. ● Don't dip the product into liquid. ● Please make sure that surface & plugs are dry before turning on. Otherwise, it may result in fire or electric shock.

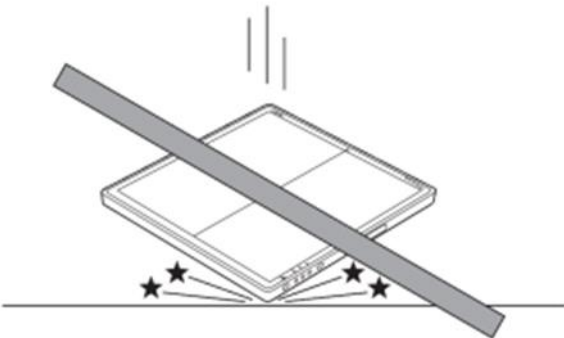
	<ul style="list-style-type: none"> ● Clean the plug of the power cord periodically by unplugging it from the AC outlet and removing dust or dirt from the plug, its periphery and AC outlet with a dry cloth. If the cord is kept plugged in for a long time in a dusty, humid or sooty place, dust around the plug will attract moisture; this could cause insulation failure that may result in a fire. ● For safety reasons, be sure to turn off the power when performing inspections indicated in this manual. Otherwise, electric shocks may occur.
CAUTION	
<p>Installation and environment of use</p> 	<ul style="list-style-type: none"> ● Do not install the product in any of the locations listed below. Doing so may result in failure, malfunction, falling, fire or injury. Close to facilities where water is used Where it will be exposed to direct sunlight Close to the air outlet of an air-conditioner or ventilation equipment Close to heat source such as a heater Where the power supply is unstable In a dusty environment In a saline or sulfurous environment Where temperature or humidity is high Where there is freezing or condensation In areas prone to vibration On an incline or in an unstable area ● Take care that cables do not become tangled during use. Also, be careful not to get your feet caught by cable. Otherwise, it may cause a malfunction of the product or injury of the user due to tripping over the cable. ● Non-medical equipment such as battery charger, access point and infrared register tools cannot be used in patient's vicinity. 

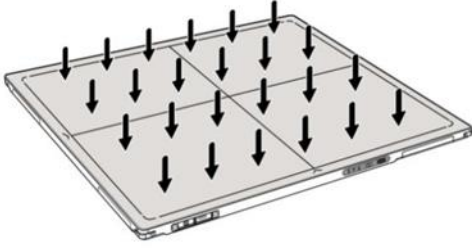
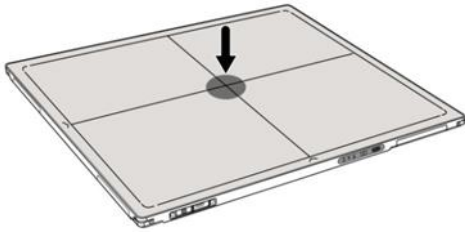
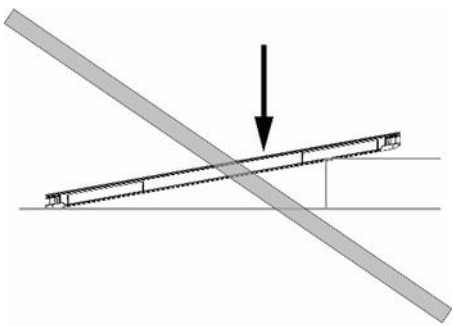
<p>Power supply</p>	<ul style="list-style-type: none"> ● Always connect three-core power cord plug to a grounded AC power outlet. ● To make it easy to disconnect the plug at any time, avoid putting any obstacles near the outlet. Otherwise, it may not be possible to disconnect the plug in an emergency. ● Be sure to ground the product to an indoor grounded connector. Also, be sure to connect all the grounds of system to common ground. ● Do not use any power source other than the one provided with the product. <p>Otherwise, fire or electric shock may be caused due to leakage.</p>
<p>Handling</p>	<ul style="list-style-type: none"> ● Do not spill liquid or chemicals onto the equipment. In case the patient is injured, it is not allowed to contact with blood or other body fluids. <p>Doing so may result in fire or electric shock.</p> <p>In such a situation, protect the equipment with a disposable cover as necessary.</p> <ul style="list-style-type: none"> ● Turn OFF the power and pull out the plug to each piece of equipment for safety when not used.
<p>CAUTION</p>	
<p>Handling</p> <div style="text-align: center;">  </div>	<ul style="list-style-type: none"> ● Handle the product carefully. ● Do not submerge the product in water. ● Only working surface meets IPX1 ● The internal image sensor may be damaged if something hits against it or it is dropped. If the product is dropped, the drop sensor inside would record and the product would not be warranted by our company. <div style="text-align: center;">  </div> <ul style="list-style-type: none"> ● Do not place excessive weight on the panel. <p>Otherwise, the internal image sensor may be damaged and image may be incorrect.</p> <p>Patients stand on the product temporarily, and the intended weight can be 135kg.</p> <p>Based on the internal TFT character, cannot load the dynamic forces due to loading from persons</p> <p><Load Limit></p>

	<p>Uniform load: 150 kg over the whole area of the surface.</p>  <p>Local load: 100 kg on an area 4 cm diameter.</p>  <ul style="list-style-type: none"> ● Be sure to use the product on flat surface so it would not bend. Otherwise, the internal image sensor may be damaged. Be sure to securely hold the product while using it in upright positions. Otherwise, the product may fall over, resulting in injury to user or patient, or may flip over, resulting in damage to the inner device.  <p>Keep the same load on the product when acquiring image. The image will be incorrect.</p>
CAUTION	
 CAUTION	<ul style="list-style-type: none"> ● Do not close to fire, do not use in high temperature ● Do not invert positive and negative pole ● Do not contact with metal in case of short circuit ● Do not insert sharp objects into battery ● Do not beat battery ● Do not stand on battery ● Do not use battery out of rules ● Do not dispose of battery or change inner structure ● Do not submerge battery in water, please keep dry in storage and do not contact with water in use ● Please charge battery with charger following GB

	<p>9706.1 Standards provided by us</p> <ul style="list-style-type: none">● Do not mix battery with ones not provided by our company● Do not charge battery with broken charger.● Substitution of battery inside main unit must be carried out by qualified people● Do not touch output connector for adaptor● Do not remove the battery when the panel is powered on only with the battery.
--	---

1.2. Notes for Using

When using the product, take the following precautions. Otherwise, problems may occur and the product may not function correctly.

Before exposure

- Be sure to check the product daily and confirm it work properly.
- Sudden heating of the room in cold areas will cause condensation on the product. In this case, wait until the condensation evaporates before performing an exposure. If it is used when condensation is formed, problems may occur in the quality of captured images. When an air-conditioner is used, be sure to raise/lower the temperature gradually to prevent condensation.
- The product should be warmed up for 15 minutes before exposure or updating the gain map and defect map.
- Make sure exposure rate is over 900nGy/s @70KV.
- Make sure wave form of the energy going to the X ray tube is square not pulse.
- Be cautious with circumstance that someone has radio isotope recently injected into them, it may cause that panel transmit image without x ray.

During exposure

- Do not move Power Cable, or it may cause image noise or artifacts, even incorrect images.
- Do not use the product near the equipment generating a strong magnetic field. Otherwise, it may cause image noise, artifacts or even incorrect images.

After usage

- It's strongly recommended to remove battery from panel if panel is not used more than 5 days. If battery stores for a long time, it should be charged (30% to 50%) every 3 month or charged (50% to 70%) every 6 month.

Contact with the patients parts cleaning, disinfection and sterilization

- After every examination, wipe the patient contact surfaces with nonflammable disinfectants to prevent the risk of infection, such as benzalkonium chloride, benzalkonium bromide. For details on how to sterilize, consult a specialist.
- Do not spray the product directly with disinfectants or detergents.
- Wipe it with a cloth slightly damped with a neutral detergent. Do not use solvents such as benzene and acid. Doing so may damage the surface of the product.
- It's recommended to use a waterproof non-woven cover as the isolated layer between product and the bleeding patient.

Applied part

- The front and back of detector is application part.

2. GENERAL DESCRIPTION	19
2.1. Scope	19
2.2. Model.....	19
2.3. Characteristic	20
2.4. Intended use/ essential performance/ application specification.....	20
2.5. Essential performance	20
2.6. The relative position between patient and detector	21
2.7. Product Components	21
2.8. Components Description.....	23
2.9. Product Specification.....	26
2.10. IT network.....	30

2. General Description

Mars1417V (configuration: Mars1417V3, hereinafter referred as Mars1417V) is a cassette-size wireless X ray flat panel detector based on amorphous silicon thin-film transistor technologies. It is developed to provide the highest quality of radiographic image, which contains an active matrix of 2304×2800 with 150um pixel pitch. The greatest feature is Mars1417V supports wireless communication between panel and Workstation. Mars1417V’s power supply includes battery. Mars1417V can be used as a real portable panel.

2.1. Scope

This manual contains information about the Mars1417V. Information in the manual, including the illustrations, is based on prototype. If your configuration does not have any of these items, information about these items does not apply to your panel.

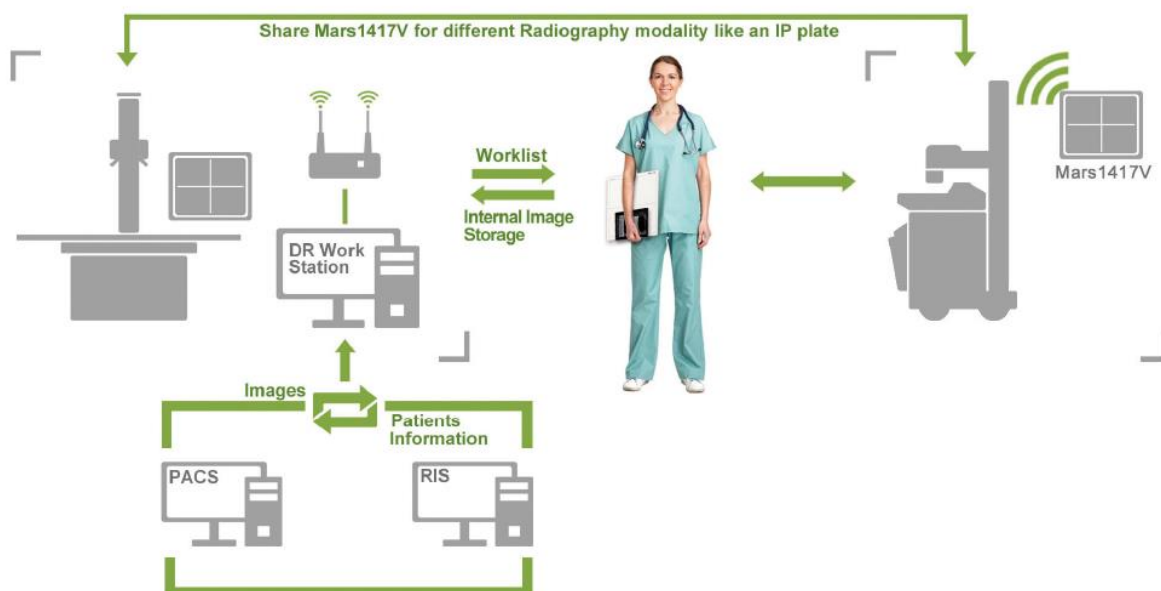

2.2. Model

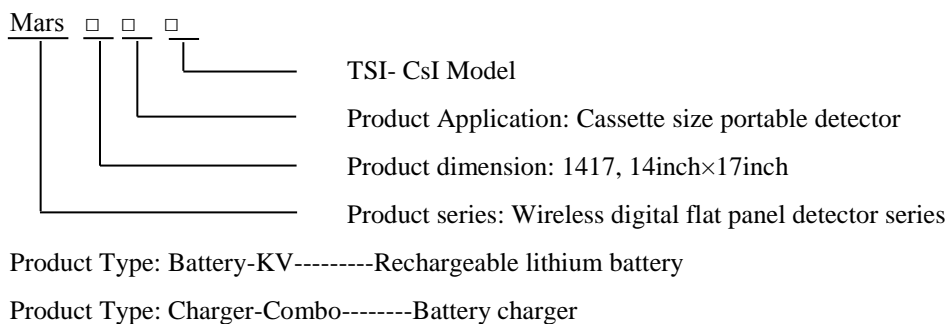

2.3. Characteristic

- Wireless static flat panel detector used for general radiography.
- Cassette-size
- Sync-shot exposure trigger
- CsI scintillation screen.
- Easy to change the cable and update firmware.
- Battery recycling

2.4. Intended use/ essential performance/ application specification

2.4.1. Intended use

Mars1417V Wireless Digital Flat Panel Detector is indicated for digital imaging solution designed for providing general radiographic diagnosis of human anatomy. It is intended to replace radiographic film/screen systems in all general-purpose diagnostic procedures. This panel provides digital X ray imaging for diagnosis of disease, injury, or any applicable health problem. The image is obtained as the result of X ray passing through the human body and detected by detector.

Our company would provide hardware and software support for integration of system.

This panel is not intended for mammography and extra-oral X-ray applications which are covered by IEC60601-2-63.

2.5. Essential performance

According to the Mars1417V series intended use and the result of risk management, getting imaging and function of data transmission is defined as essential performance.

Getting qualified dark image proves that essential performance does not influence intended use. Method for getting dark image in detail refers to section “install” and “operation”.

2.5.1. Application specification

PATIENT population:

Age: except for children

Weight: not relevant

Health: not relevant

Nationality: multiple

Patient state: patient is not user

Gender: except for pregnant women

Intended OPERATOR:

All of use, maintenance and operation steps should be carried out by the operator who has accepted the professional training offered by the company's customer service staff.

Life-time:

Life-time: 7 years without frequency limit

2.6. The relative position between patient and detector



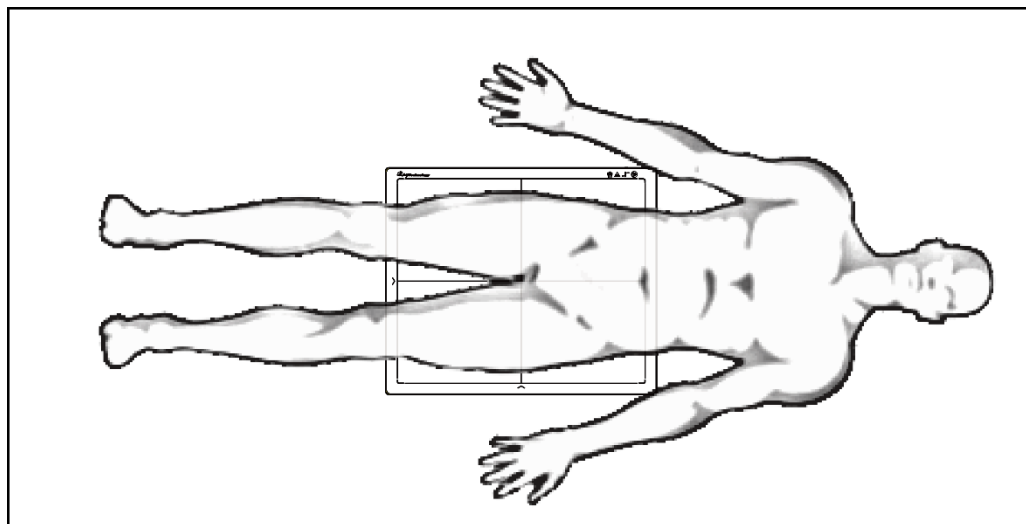



Because of the crosstalk effect of Amorphous silicon flat-panel detector, Pay attention to the relative position of patient and detector, the recommended position as shown below, Otherwise, the image is prone to abnormal light lines.

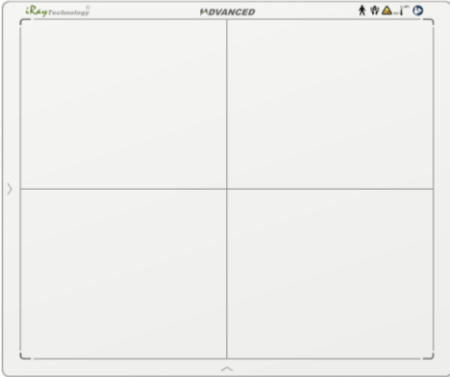

2.7. Product Components

Mars1417V comes with both DC power supply and battery package. Once powered on, it would build a connection with Workstation through Ethernet cable (only for service) or Wireless connection.

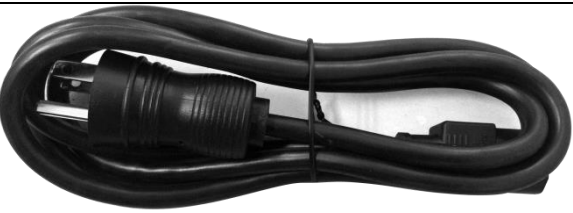
	Item	Description
Mars1417V Detector		1pcs Main Unit

<p>Medical Adapter</p>		<p>1 pcs DC 24V</p>
<p>Battery</p>		<p>2 pcs Battery pack</p>
<p>Ethernet Cable (Only for service)</p>		<p>1pcs 3.5 m</p>
<p>Gigabit Ethernet Cable</p>		<p>1pcs 3 m</p>
<p>AC Power Cable</p>		<p>1 pcs</p>
<p>DC Power Cable</p>		<p>1 pcs 3.5 m</p>

C	Detector Indicator	Detector indicator of control panel
D	Power Button	Power button of control panel
E	reserved	/
F	Antenna	Antenna

2.8.2. Battery

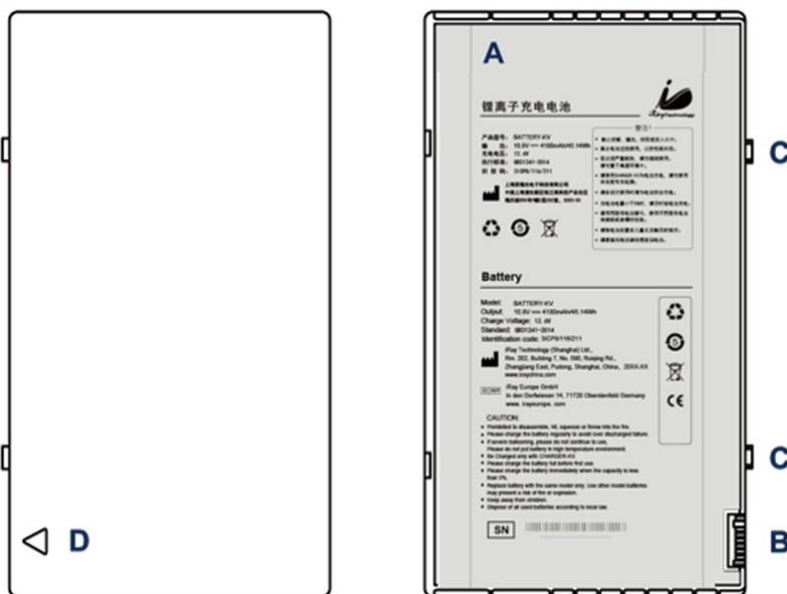

Item	Name	Description
A	Battery Label	/
B	Battery Interface	8 Pin Battery connector
C	Pilot Pin	/
D	Indicator	Installation direction indicator

2.8.3. Battery Charger



Item	Name	Description
A	Battery Interface A	8 Pin Battery connector
B	Battery Interface B	5 Pin Battery connector
C	Battery Interface C	5 Pin Battery connector
D	Indicator	The indicator definition is as follow
E	The limit ball plug	/
F	Hand Pull Position	/
G	AC Jack	220V AC input

The battery charger indicator definition:

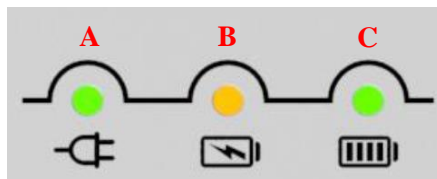

Item	Name	Description
A	Power Indicator	/
B	Charging Indicator	/
C	Charge Full Indicator	/

X Indicator	Lighting Status	Operating Status
All off		No power input
A indicator on		<ul style="list-style-type: none"> ● AC Power input ● Multiple batteries inserted
A indicator on B and C alternately blink 2 times		Battery insertion self-test
A and B indicator on		Battery Charging
A and C indicator on		Battery capacity full, charging stops
A indicator on B and C alternately blinking		Battery charging abnormal

Two or more battery charging at the same time is prohibited, if inserted at the same time, the charger will automatically stop working.

2.9. Product Specification

2.9.1. Detector

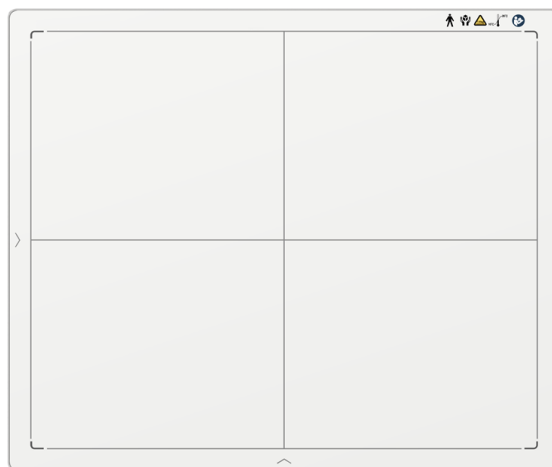

Item	Specification
Model	Mars1417V-TSI (CsI)
Image Sensor	a-Si (Amorphous Silicon) TFT
Pixel Size	150 μm
Active Array	2304 x 2800
Active Area (H x V)	345.6mm x 420mm
Gray scales	16bit
Spatial Resolution	3.3 Lp/mm
Image Acquisition Time (Wireless) Both AP mode and Client mode	Preview Acquisition Time: 3 sec. Processed Acquisition Time : 5 sec.
Cycle Time	Min. 8s
Power Consumption	Max. 18W
Dimension (L x W x H)	460 x 384 x 15 mm
Weight (with one battery)	3.43 kg
Image Transfer	Wireless : IEEE802.11a/b/g/n/ac
Data Transmission Rate (Wireless)	802.11b: Max. 11Mbps 802.11a/g: Max. 54Mbps 802.11n: Max. 300Mbps (MIMO 2x2) 802.11ac: Max. 867Mbps(MIMO 2x2)

2.9.2. Battery

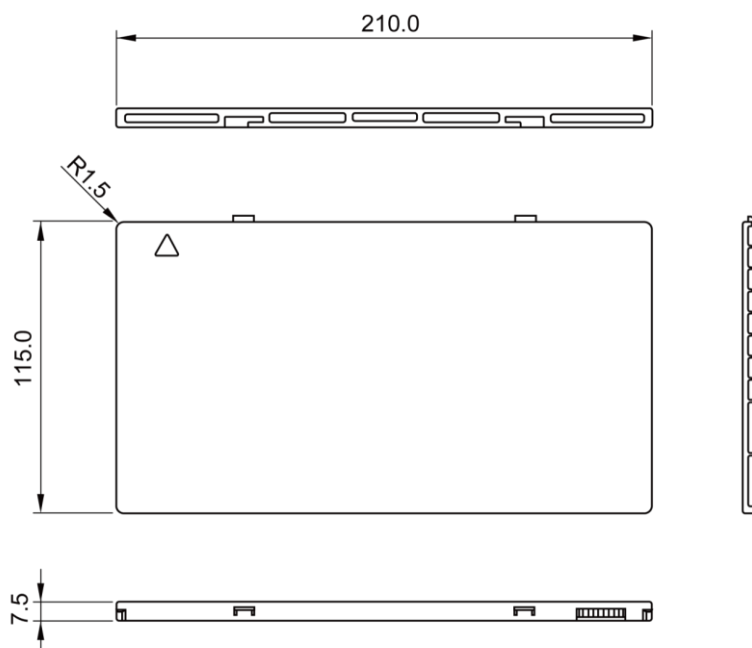

Item	Specifications
Model	Battery-KV
Rated Capacity	Typ. 4180mAh @ Discharge 0.2C
Nominal Voltage	10.8V
Charge Voltage	12.6±0.05V
Discharged End Voltage	9V
Charging Method	CC-CV
Operating Temperature	Charge 0°C-+60°C, Discharge-10°C-+60°C
Storage Temperature	≤3 month -20°C-+45°C ≤6 month -20°C-+35°C
Relative Humidity	5%~95%
Dimension (L × W × H)	210 x 115 x 7.5 mm
Weight	0.28kg

2.9.3. Battery Charger



Item	Specifications
Model	Charger-Combo
Simultaneous Charging	1 battery packs
Full charging time	≤3 hours
Rated power supply	90~264V(AC)
Dimension (L × W × H)	240 x 184 x 38 mm
Weight	0.55 kg

2.9.4. Power supply

Mars1417V supports both DC Power and Battery package input.

Item	Specifications
DC Power	24V(DC), 0.75A
Battery Package	10.8V(DC),1.6A

The product must be used with the approved adaptor whose CB certificate number is SG PSB-MD-00191.

2.9.5. AP Router

Mars1417V do not include AP Router. Users can choose AP Router as they wish, however specification below is a requirement.

Item	Specifications
Wireless Standard	IEEE 802.11 a/b/g/n/ac
Frequency Range	2.412 ~ 2.4835 GHz and 5.15 ~ 5.85 GHz
Wireless Data Rate	802.11b: Max. 11Mbps 802.11a/g: Max. 54Mbps 802.11n: Max. 300Mbps (MIMO 2x2) 802.11ac: Max. 867Mbps(MIMO 2x2)

2.9.6. Wireless Communication

Item	Description
Wireless Standard	IEEE 802.11a/b/g/n/ac
Frequency Range	2.412~2.472GHz: ch1~ch13 5.18~5.24GHz: ch36~ch48 5.745~5.85GHz: ch149~ch165
Data Transmission Rate	802.11b: Max. 11Mbps 802.11a/g: Max. 54Mbps 802.11n: Max. 300Mbps (MIMO 2x2) 802.11ac: Max. 867Mbps(MIMO 2x2)
Modulation	802.11b: CCK, DQPSK, DBPSK 802.11a/g/n: 64 QAM, 16 QAM, QPSK, BPSK 802.11ac: 256 QAM, 64 QAM, 16 QAM, QPSK, BPSK
Transmission Power	Max.17dBm
Security	WPA, WPA-PSK, WPA2, WPA2-PSK, WEP 64bit & 128bit
Antenna	2 Dual Band inner antenna

2.9.7. Recommended Application Condition

Item	Description
Operating System	Windows 7 32/64bit
CPU	Intel Core i7 3.6G
Memory	4G DDR3
Hard Disk	640 G
LAN Card	Intel Pro EXP9301CT PRO

2.9.8. Mechanical Outlines

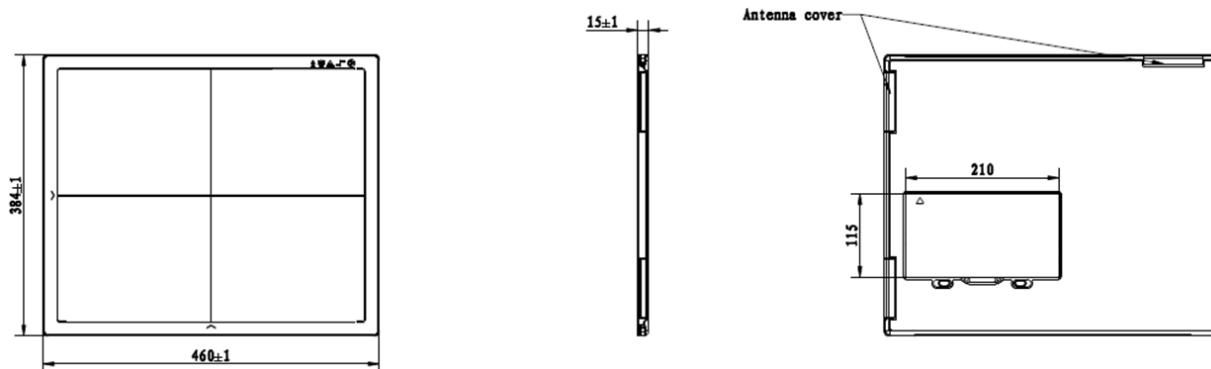

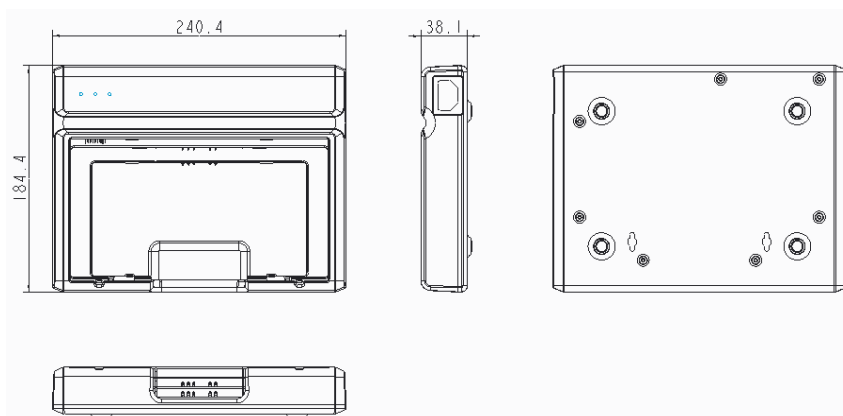

2.9.9. Use Environment

	Temperature	Temperature change	Humidity	Atmospheric Pressure	Pressure Change
Operating	5~35℃	<1k/min	10%~90% RH	700~1060hPa	<10kp/min (1kp=1.0197E-5Pa)
Storage	-20~55℃	<1k/min	5%~95% RH	700~1060hPa	<10kp/min (1kp=1.0197E-5Pa)

The Mars1417V serial detectors shall operate at an altitude specified not more than 3000m, the environment is only for detector.

2.10. IT network

2.10.1. Purpose for IT-network

Transmission between the detector and the workstation is image data and command/status communication.

2.10.2. Required characteristics

Wireless communication follows IEEE 802.11a/b/g/n/ac protocol. It works on 2.4GHz and 5GHz.

It supports at least 2 routers.

2.10.3. Required configuration

The wireless card and the detector must work on the same IP segment such as 192.168.8.XXX
They must support IEEE 802.11a/b/g/n/ac.

2.10.4. Technical specifications

Item	Description
Wireless Standard	IEEE 802.11a/b/g/n/ac
Frequency Range	2.412~2.472GHz: ch1~ch13
	5.18~5.24GHz: ch36~ch48
	5.745~5.85GHz: ch149~ch165

Data Transmission Rate	802.11b: Max. 11Mbps 802.11a/g: Max. 54Mbps 802.11n: Max. 300Mbps (MIMO 2x2) 802.11ac: Max. 867Mbps(MIMO 2x2)
Modulation	802.11b: CCK, DQPSK, DBPSK 802.11a/g/n: 64 QAM, 16 QAM, QPSK, BPSK 802.11ac: 256 QAM, 64 QAM, 16 QAM, QPSK, BPSK
Security	WPA, WPA-PSK, WPA2, WPA2-PSK, WEP 64bit & 128bit

2.10.5. Intended information flow

The detector sends image data acquired to the workstation. The workstation sends users' commands to the detector. Please refer to the operation manual of the Console for detail.

2.10.6. Hazardous situations resulting from failure of the IT-network

1. Failure of completing essential performance
2. Failure of finishing configuration of product
3. Operating system is not compatible
4. Change or update software failed
5. Compatibility of interface
6. Data transfer protocol error
7. Inconsistency of interface or format leads to data distortion;
8. Data output failed;

2.10.7. Warning

Connection of the main unit to an IT-network that includes other equipment could result in previously unidentified risks

The manufacturer of x-ray machine should identify, analyze, evaluate and control these risks; subsequent changes to the IT-network could introduce new risks and require additional analysis

2.10.8. Changes to the IT-network include

1. Changes in the IT-network configuration;
2. Connection of additional items to the IT-network;
3. Disconnecting items from the IT-network;
4. Update of equipment connected to the IT-network;

3. INSTALLATION	33
3.1. Panel Installation.....	33
3.1.1. Attach Battery Pack	33
3.1.2. Attach DC Power	33
3.1.3. Booting Up.....	34
3.1.4. Button function.....	36
3.2. Battery Charger Installation.....	36
3.3. Battery lock and activation	37
3.4. Software Installation.....	38
3.5. Panel Infrastructure.....	38
3.5.1. Wireless Client Mode	38
3.5.2. Wireless AP Mode	42

3. Installation

3.1. Panel Installation

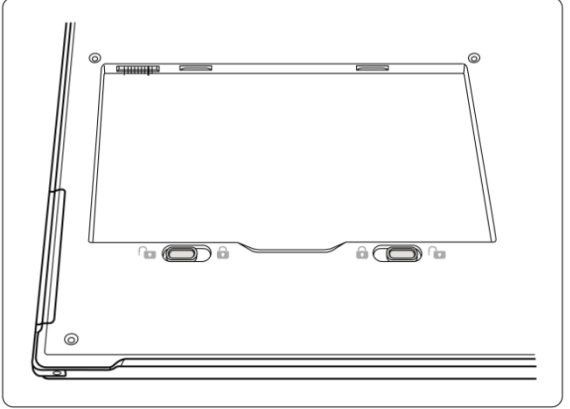
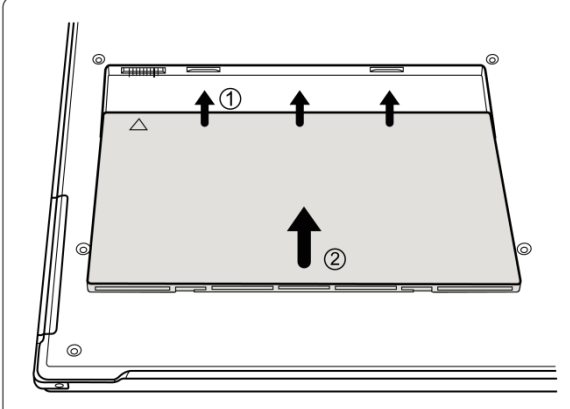
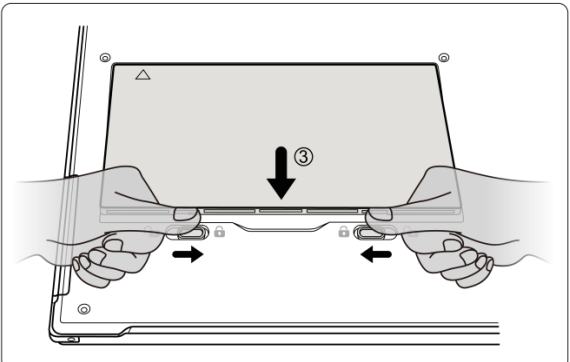

3.1.1. Attach Battery Pack

Mars1417V can be powered by both battery package and DC power. Once battery package is inserted or DC power is on, Panel would be activated immediately. If none of battery and DC power is on, Mars1417V would power off. Please see below for battery installation.

<p>Make sure that the connectors on the battery package are pointed to the cave in battery compartment.</p>	 A line drawing of the Mars1417V panel's battery compartment. It shows a rectangular opening with two locking mechanisms at the bottom. The top edge of the compartment has several small rectangular connectors. The panel is shown from a top-down perspective.
<p>Slide battery package into battery compartment (Make sure battery capacity overpass 10%) .</p>	 A line drawing of the Mars1417V panel's battery compartment. A shaded rectangular battery package is being inserted into the compartment. Three upward-pointing arrows labeled '1' are positioned above the package, and one larger upward-pointing arrow labeled '2' is positioned below the package, indicating the direction of insertion.
<p>Slide the battery lock lever.</p>	 A line drawing of the Mars1417V panel's battery compartment. A shaded rectangular battery package is now fully inserted. Two hands are shown at the bottom of the compartment, one on each side, sliding the lock levers inward. A downward-pointing arrow labeled '3' is positioned above the package, indicating the direction of the lock lever movement.

3.1.2. Attach DC Power

Please see below for DC power installation.





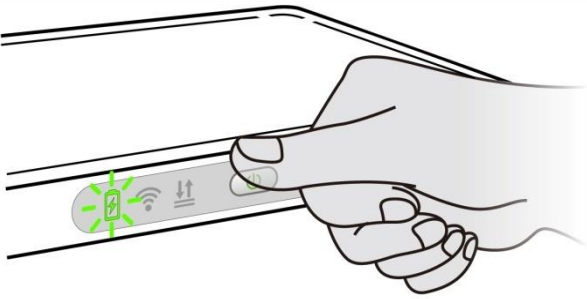

<p>Connect one end of DC Power Cable to the Medical Adapter</p>	
<p>As figure is power interface Ethernet interface</p>	
<p>Connect another end of DC Power Cable to the DC input of the detector.</p>	

3.1.3. Booting Up





On the control panel, user can press power button to power on/off.

<p>If panel is powered off, user can press the button for 4 seconds to power on when battery is inserted and battery capacitor is no less than 10%, or DC power is connected.</p> <p>If panel is powered on, user can press the button for 4 seconds to shut down. On the other hand, it can also be used as reset inner control IC when button is active for 7s.</p>	
---	--



After booting up, user can check the status LED indicator.



Power Indicator	Lighting Status	Operating Status		
		Operating	Battery Capacity	DC Input
OFF		Power OFF	/	/
Orange ON		Power ON	≤20%	NO
Green ON		Power ON	<ul style="list-style-type: none"> Battery capacity ≥20%, no DC input DC input, no Battery 	
Orange Blinking		Power OFF	<20%	YES
Green and Orange Blinking		Power OFF	≥20% and <95%	YES
Green Fast Blinking		Power OFF	≥95% and <100%	YES
OFF		Power OFF	=100%	YES

Link indicator is as table:

Link Indicator	Lighting Status	Description
OFF		<ul style="list-style-type: none"> Shut down wired connection broken and wireless connection not ready
Green ON		<ul style="list-style-type: none"> Wired Connection is built
Blue ON		<ul style="list-style-type: none"> Client mode, wireless connection is built AP mode, wireless AP is ready
Blue Blinking		<ul style="list-style-type: none"> Client mode, no connection is built
Green and Blue Blinking		<ul style="list-style-type: none"> Initialization

Status indicator is as table:

Status Indicator	Lighting Status	Description
OFF		<ul style="list-style-type: none"> Shut down Exposure prohibit
Green ON		<ul style="list-style-type: none"> Exposure enable
Green Blinking		<ul style="list-style-type: none"> Image transmission

Orange ON		● Error
Orange Blinking		● Safety mode

3.1.4. Button function

The Button function is shown as table below

Action	FPD Status	Power	Note
			
N.A.	/	No-Action	
Power ON	Power OFF	Short-Hold	Hold for 4 seconds.
Forced Restart		Long-Hold	Hold for more than 7 seconds, Release Power Key when the POWER indicator is ON.
Exit the battery from ship mode		Triple-Click	Release after three short presses (interval <1s)
Forced Restart	Power ON	Long-Hold	Hold for more than 7 seconds, when the POWER indicator is OFF and then ON, Release Power Key.
Enter/Exit Sleep Mode		Double-Click	Release after two short presses (interval <1s)
Power OFF		Short-Hold	Hold for 4 seconds, Release Power Key when the POWER indicator is OFF.

3.2. Battery Charger Installation

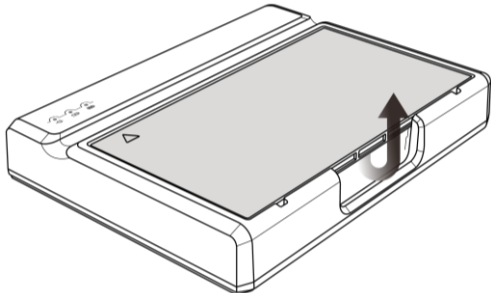
Operation	Figure
Unload Battery from battery charger.	

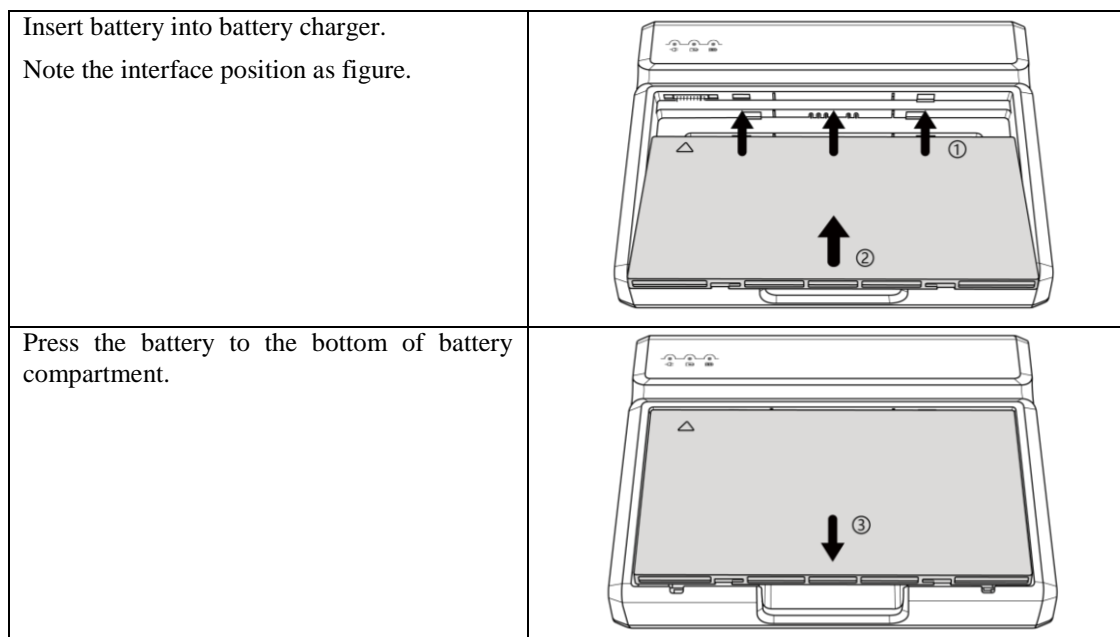

3.3. Battery lock and activation

To ensure the safety of the battery during transportation or storage, the battery can be set to ship mode, that is, the battery is locked without voltage output. So, it needs to exit ship mode before using the battery for the first time.

● **Two ways to enter ship mode**

Item	Steps
factory configuration	/
Web write in	<ul style="list-style-type: none"> ● Power the panel with adaptor, and turn on it, then connected it to the PC; ● Insert the battery; ● Type “http://192.168.8.8/cgi-bin/shipmode.cgi?action=on” in the Web to enter ship mode

● **Three ways to exit ship mode**

Item	steps
Web exit	<ul style="list-style-type: none"> ● Power the panel with adaptor, and turn on it, then connected it to the PC; ● Insert the battery; ● Type “http://192.168.8.8/cgi-bin/shipmode.cgi?action=off” in the Web to exit ship mode
Adaptor + FPD	<ul style="list-style-type: none"> ● Power the panel with adaptor, and turn on it; ● Insert the battery; ● Press the power button about 4s to shut down the detector; ● In the shutdown state, press the power button for 3 times to exit ship mode.
Charger	<ul style="list-style-type: none"> ● Power on charger; ● Insert the battery into the charger for 3~5s to exit ship mode

3.4. Software Installation

In the case of iDetector not work, please install Microsoft .NET Framework 4.5 first, then install vcredist_x86_2013 (or vcredist_x64_vs2013) . (iDetector should not be used for terminal hospital)

3.5. Panel Infrastructure

Mars1417V supports two connection modes as follows, the IP address and other information mentioned below is as the example, user should configure the connection with the specific requirement.

1) Wireless Client Mode

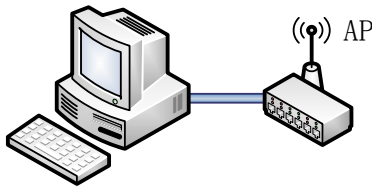

2) Wireless AP Mode

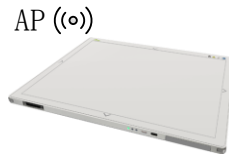
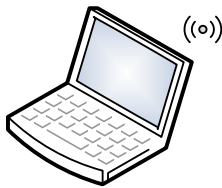

To build connection between workstation and Panel, User should follow steps below.

3.5.1. Wireless Client Mode

To complete Wireless Client mode configuration, user has to finish actions listed below.

Configuration of External wireless AP

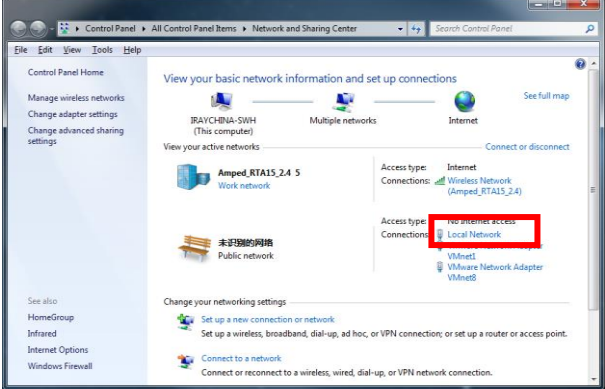
<p>Connect one end of Gigabit Ethernet Cable to Workstation, Connect another end to LAN port of External wireless AP</p>	<p>/</p>
<p>Open local network management interface</p>	

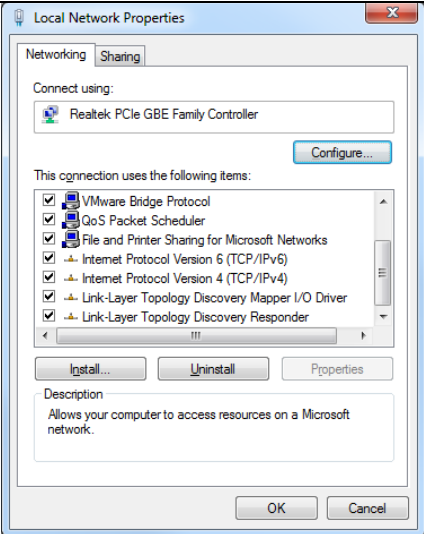
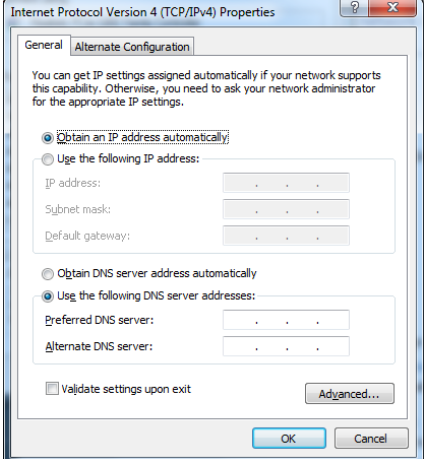
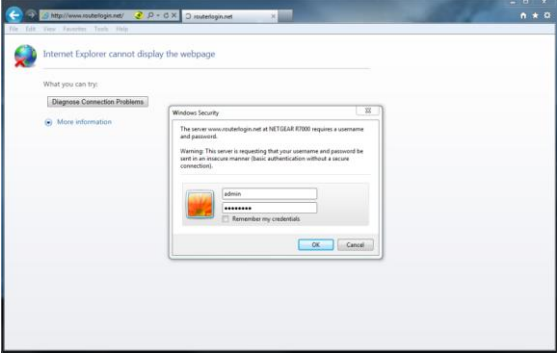
<p>Open local network configuration</p>	
<p>open IPV4 setting</p>	
<p>IP and network mask setting</p>	<p>Select "Obtain an IP address automatically"</p>
<p>Open browser and type 192.168.1.1 Log into external wireless AP</p>	

<p>Wireless setup</p>	
<p>Configure 2.4GHz wireless network</p>	<p>SSID: NETGEAR_BIG_24 Security: WPA2-PSK Password: 12345678 Channel: [Please check the current Wi-Fi environment, and choose a relatively clean channel]</p>
<p>Configure 5GHz wireless network</p>	<p>SSID: NETGEAR_BIG_50 Security: WPA2-PSK Password: 12345678 Channel: [Please check the current Wi-Fi environment, and choose a relatively clean channel]</p>
<p>LAN setup</p>	
<p>Configure LAN IP address</p>	<p>IP address: 192.168.8.1 Subnet Mask: 255.255.255.0</p>
<p>External wireless AP reboot</p>	<p>Apply above settings and reboot your wireless router.</p>

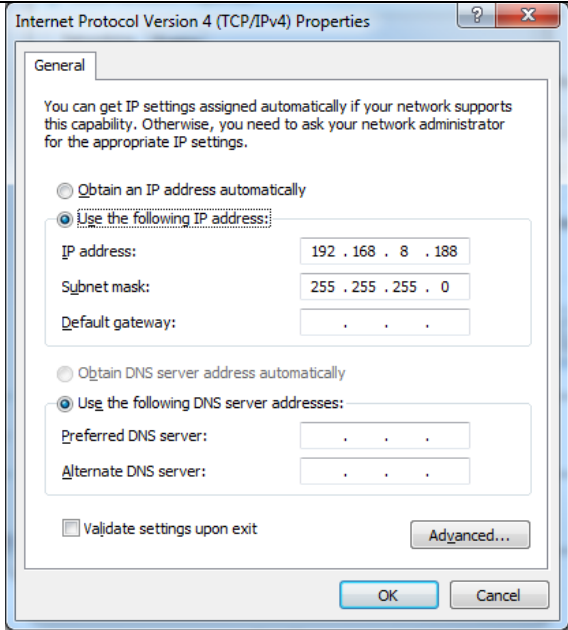
<p>Recover local network IPv4 setting</p>	
<p>IP setting Network mask setting</p>	<p>IP address: 192.168.8.188 Subnet mask: 255.255.255.0</p>

Configuration of detector

Either Wired Cable can be used to configure detector in wireless client mode. The wired connection should be used by the service operator only.

To start configuration with wired cable. It is necessary to finish the configuration of external wireless AP, then proceed to the steps below.

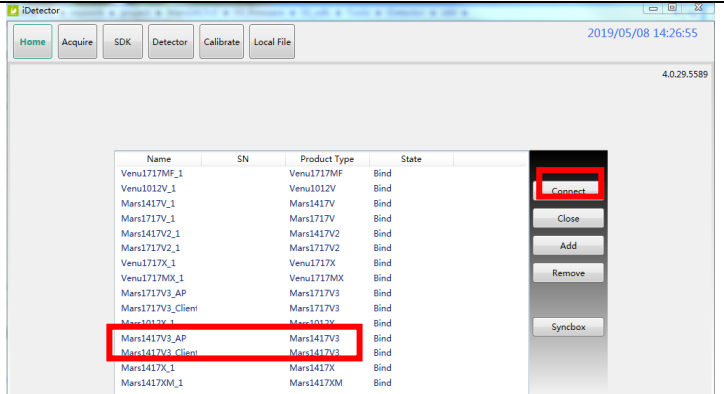
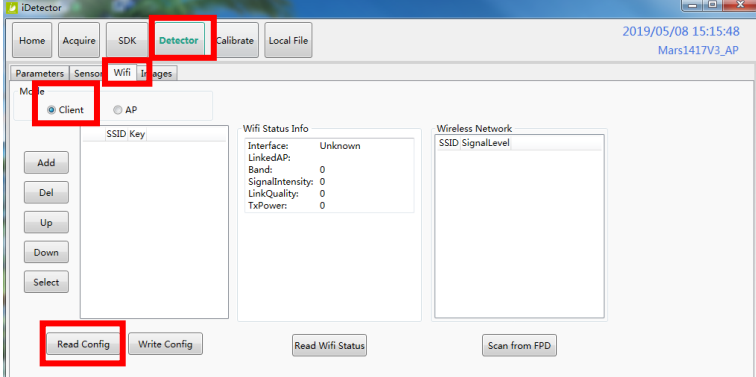
<p>Connect panel to Workstation with Ethernet Cable like 3.4.1</p>	
<p>Click "Detector" Click "Wifi" Click "Read Config" Choose "Client" mode</p>	

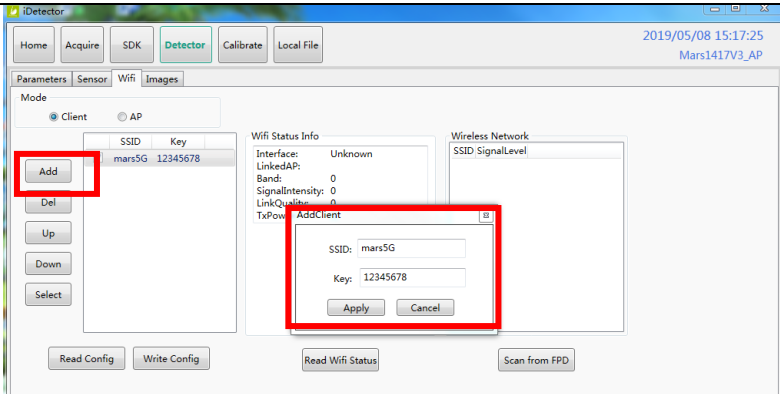
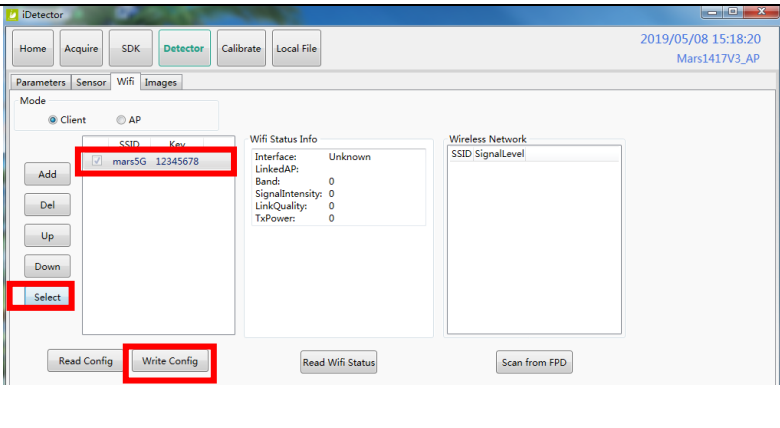
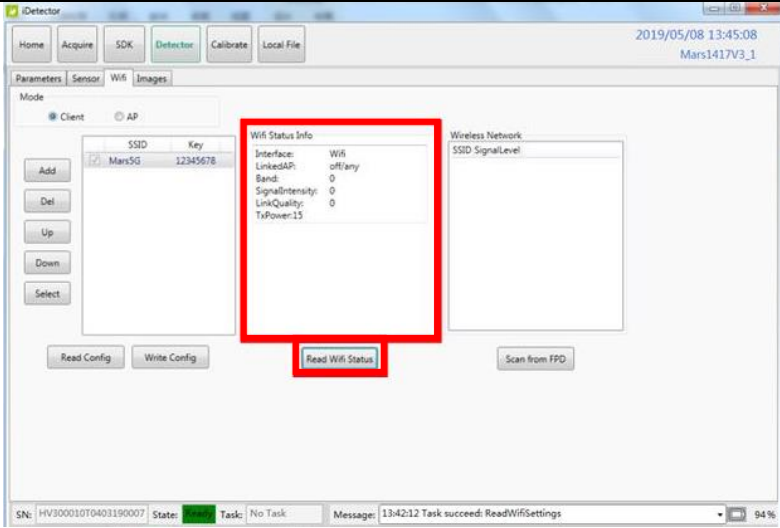
<p>Click “Add” Type SSID and Password Click “Apply”</p>	
<p>Choose SSID and select(There will be ✓ occurred)” Click “write config” to save parameters.</p>	
<p>Turn on wireless router. Make sure there are wired connection between router and work station and IP 192.168.8.188. Click “Read wifi Status” to check wireless transmission status, numericl value occurred means the link is up and available.</p>	

Since we have chosen default SSID and password, it would connect to wireless AP immediately after powered on next time.

3.5.2. Wireless AP Mode

To complete wired connection configuration, user has to finish actions listed below.

Configuration of detector

Either Wired cable can be used to configure panel wireless AP mode. The wired connection should be used by the service operator only.

To start wired cable configuration, users should finish the configuration of external wireless AP, then proceed to the steps below.

Connect panel to Workstation with Ethernet Cable like 3.4.1

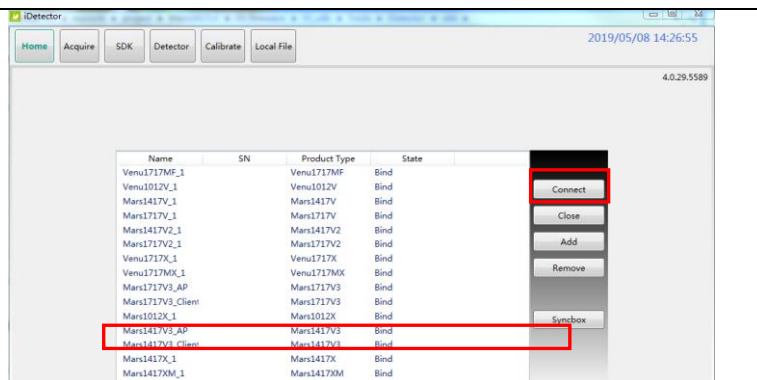

Click “Detector”
Select “wifi”
Choose AP mode

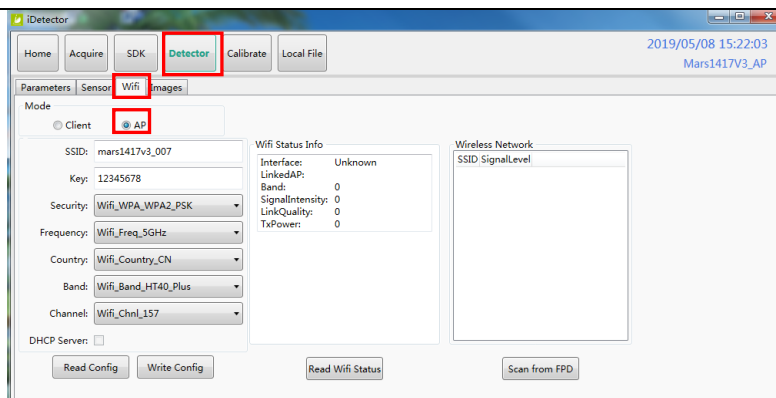

Click “Read Config” to get default setting. Change SSID and password setting , make sure SSID is different from other already exist;

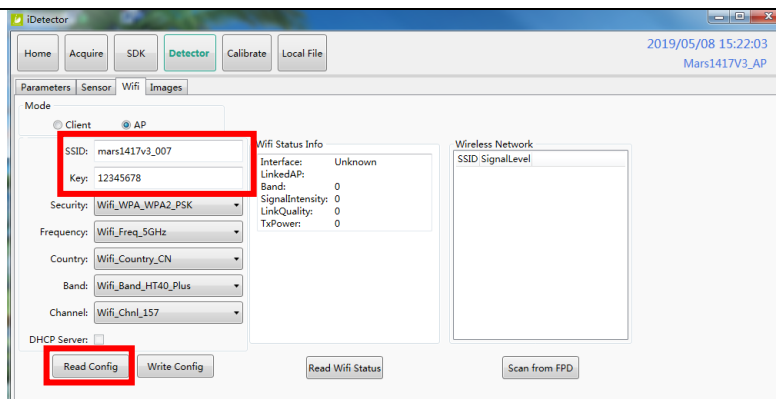

Change channels and frequency setting

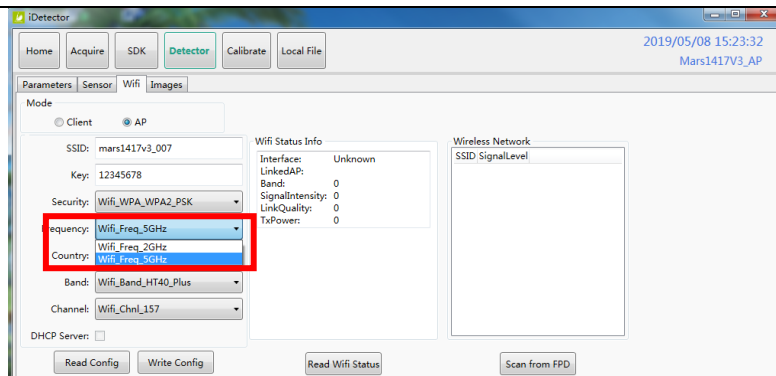

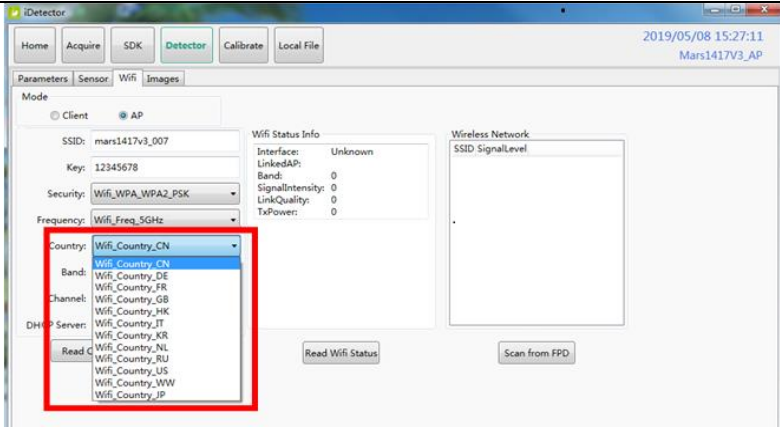
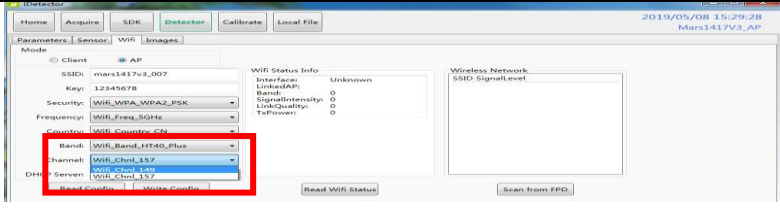
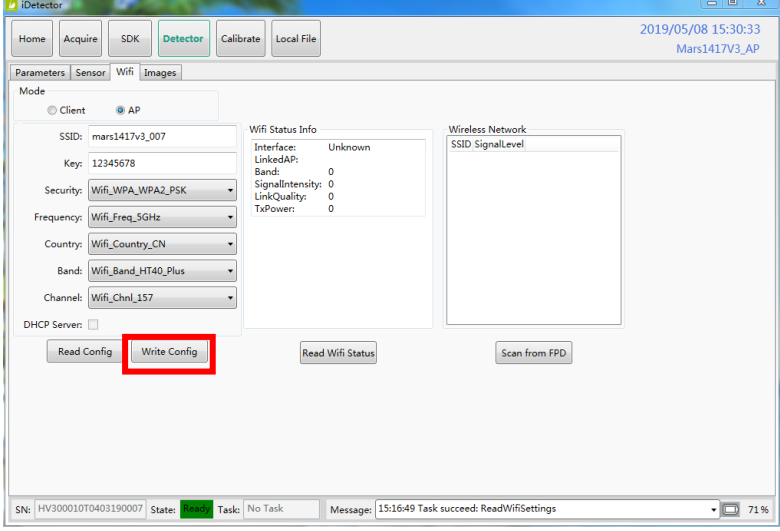
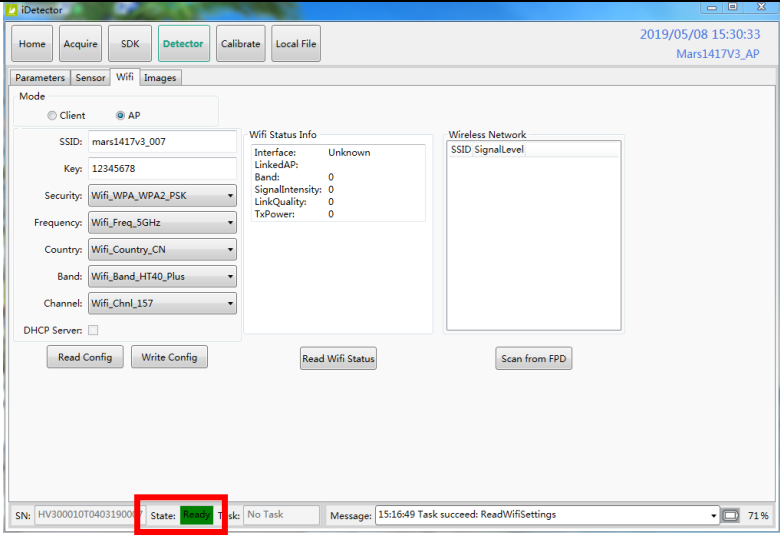
<p>Click "Country" and choose a country setting</p>	
<p>Click "Channel" and choose a clean frequency and channel</p>	
<p>Click "write config"</p>	
<p>Do not remove wired cable until FPD status from Busy become Ready</p>	

Since we have chosen default SSID and password, it would connect to wireless AP immediately after powered on next time.

Configuration of external wireless card

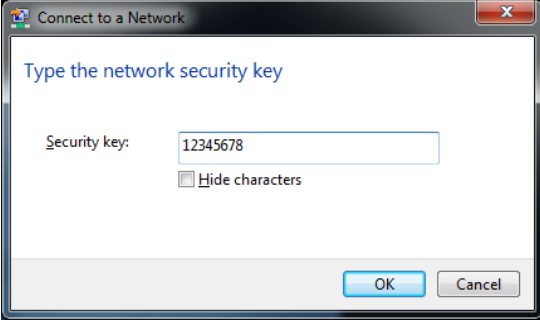
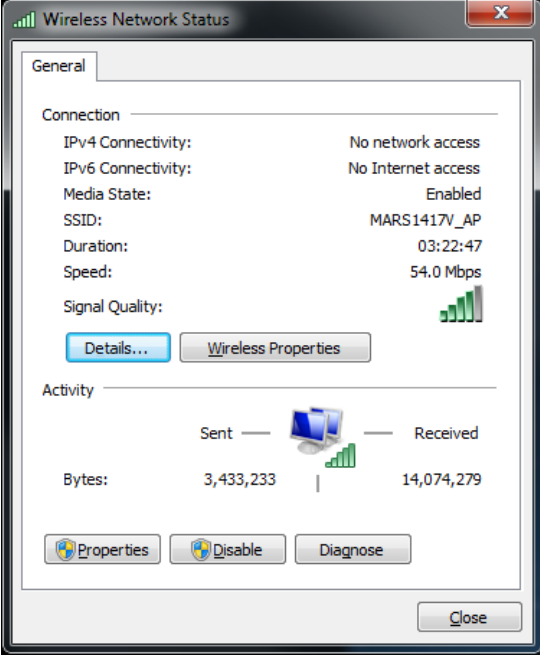
<p>Open local wireless signal list</p>	
<p>Select SSID which belongs to detectors; Input password and log into system</p>	
<p>Open wireless card configuration</p>	

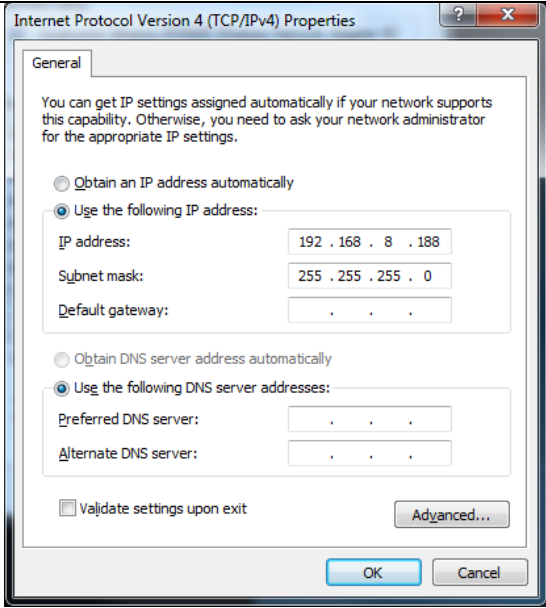
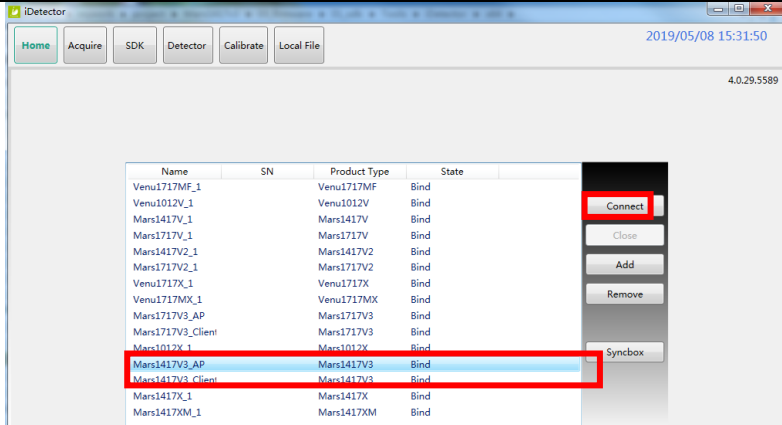
<p>open IPV4 setting</p>																																																																	
<p>IP setting Network mask setting</p>	<p>IP address: 192.168.8.188 Subnet mask: 255.255.255.0</p>																																																																
<p>Open SDK and choose product start connection</p>	 <table border="1" data-bbox="799 1088 1257 1346"> <thead> <tr> <th>Name</th> <th>SN</th> <th>Product Type</th> <th>State</th> </tr> </thead> <tbody> <tr><td>Venu1717MF_1</td><td></td><td>Venu1717MF</td><td>Bind</td></tr> <tr><td>Venu1012V_1</td><td></td><td>Venu1012V</td><td>Bind</td></tr> <tr><td>Mars1417V_1</td><td></td><td>Mars1417V</td><td>Bind</td></tr> <tr><td>Mars1717V_1</td><td></td><td>Mars1717V</td><td>Bind</td></tr> <tr><td>Mars1417V2_1</td><td></td><td>Mars1417V2</td><td>Bind</td></tr> <tr><td>Mars1717V2_1</td><td></td><td>Mars1717V2</td><td>Bind</td></tr> <tr><td>Venu1717X_1</td><td></td><td>Venu1717X</td><td>Bind</td></tr> <tr><td>Venu1717MX_1</td><td></td><td>Venu1717MX</td><td>Bind</td></tr> <tr><td>Mars1717V3_1</td><td></td><td>Mars1717V3</td><td>Bind</td></tr> <tr><td>Mars1717V3_Client</td><td></td><td>Mars1717V3</td><td>Bind</td></tr> <tr><td>Mars1012X_1</td><td></td><td>Mars1012X</td><td>Bind</td></tr> <tr><td>Mars1417V3_1</td><td></td><td>Mars1417V3</td><td>Bind</td></tr> <tr><td>Mars1417V3_Client</td><td></td><td>Mars1417V3</td><td>Bind</td></tr> <tr><td>Mars1417X_1</td><td></td><td>Mars1417X</td><td>Bind</td></tr> <tr><td>Mars1417XM_1</td><td></td><td>Mars1417XM</td><td>Bind</td></tr> </tbody> </table>	Name	SN	Product Type	State	Venu1717MF_1		Venu1717MF	Bind	Venu1012V_1		Venu1012V	Bind	Mars1417V_1		Mars1417V	Bind	Mars1717V_1		Mars1717V	Bind	Mars1417V2_1		Mars1417V2	Bind	Mars1717V2_1		Mars1717V2	Bind	Venu1717X_1		Venu1717X	Bind	Venu1717MX_1		Venu1717MX	Bind	Mars1717V3_1		Mars1717V3	Bind	Mars1717V3_Client		Mars1717V3	Bind	Mars1012X_1		Mars1012X	Bind	Mars1417V3_1		Mars1417V3	Bind	Mars1417V3_Client		Mars1417V3	Bind	Mars1417X_1		Mars1417X	Bind	Mars1417XM_1		Mars1417XM	Bind
Name	SN	Product Type	State																																																														
Venu1717MF_1		Venu1717MF	Bind																																																														
Venu1012V_1		Venu1012V	Bind																																																														
Mars1417V_1		Mars1417V	Bind																																																														
Mars1717V_1		Mars1717V	Bind																																																														
Mars1417V2_1		Mars1417V2	Bind																																																														
Mars1717V2_1		Mars1717V2	Bind																																																														
Venu1717X_1		Venu1717X	Bind																																																														
Venu1717MX_1		Venu1717MX	Bind																																																														
Mars1717V3_1		Mars1717V3	Bind																																																														
Mars1717V3_Client		Mars1717V3	Bind																																																														
Mars1012X_1		Mars1012X	Bind																																																														
Mars1417V3_1		Mars1417V3	Bind																																																														
Mars1417V3_Client		Mars1417V3	Bind																																																														
Mars1417X_1		Mars1417X	Bind																																																														
Mars1417XM_1		Mars1417XM	Bind																																																														

4. OPERATION	48
4.1. Main Operation	48
4.2. Connection Build	53
4.3. Panel Configuration.....	54
4.4. Correction and Calibration Template Generation	55
4.5. Image Check and upload	60
4.6. Defect Template Check and Modification.....	61
4.7. Correction and Calibration Management.....	64
4.8. Firmware Update	66
4.10. Software.....	74
4.11. List of the HAZARDOUS SITUATIONS resulting from a failure of the IT- NETWORK.....	79

4. Operation

Mars1417V provides SDK for user to integrate panel into their DR system. Additionally, it also provides an application for demonstration, i.e. iDetector. User can use iDetector to control panel without DR system.

4.1. Main Operation

To Acquire X ray image is the main operation of Mars1417V. Most importantly, panel should build synchronization with X ray generator. Mars1417V is born with three ways to acquire x ray image, that is Software Mode, Inner2 Mode, and FreeSync Mode.

4.1.1. Software Mode

4.1.1.1. Block Diagram

Software mode is the basic way to acquire x ray image. Please see figure below for general feature.

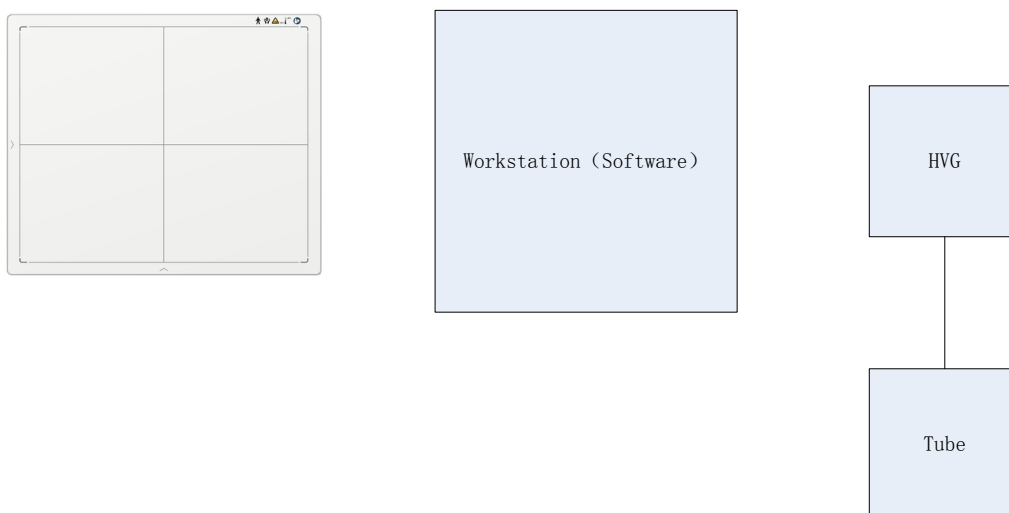

Workstation is a host device installed with iDetector and SDK. Chapter 3 has described how to establish connection between panels and workstation. In software mode, workstation does not control x ray generator. Users would decide when to shoot x ray.

4.1.1.2. Work flow

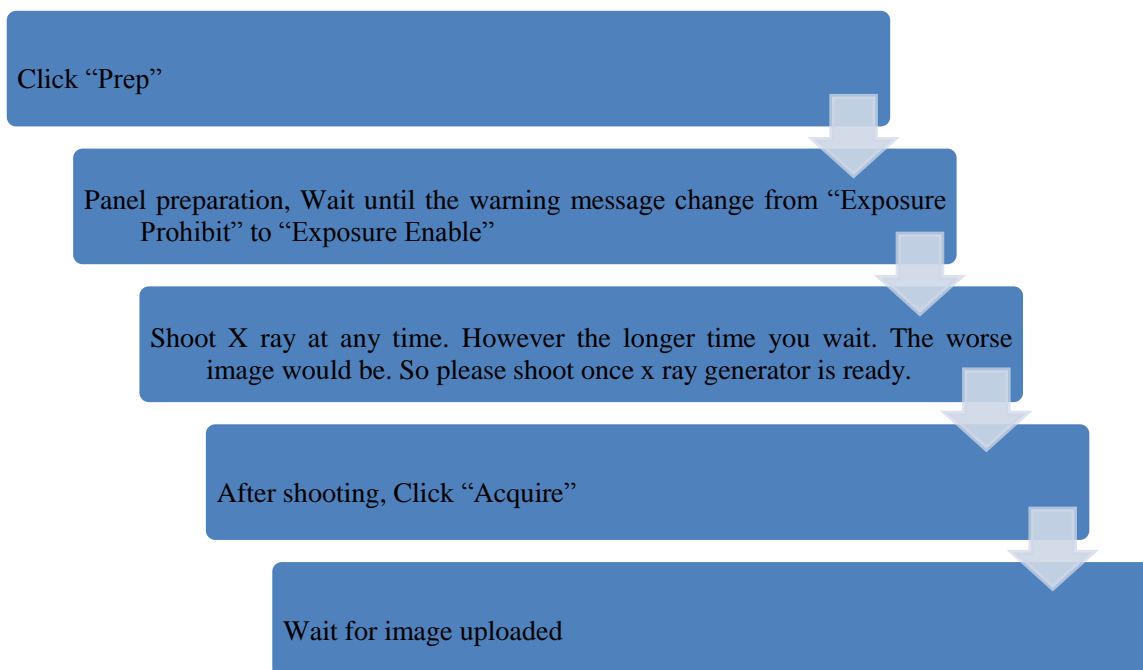

4.1.1.3. Timing Setting

To set a clear scenario for programming, see diagram below for details

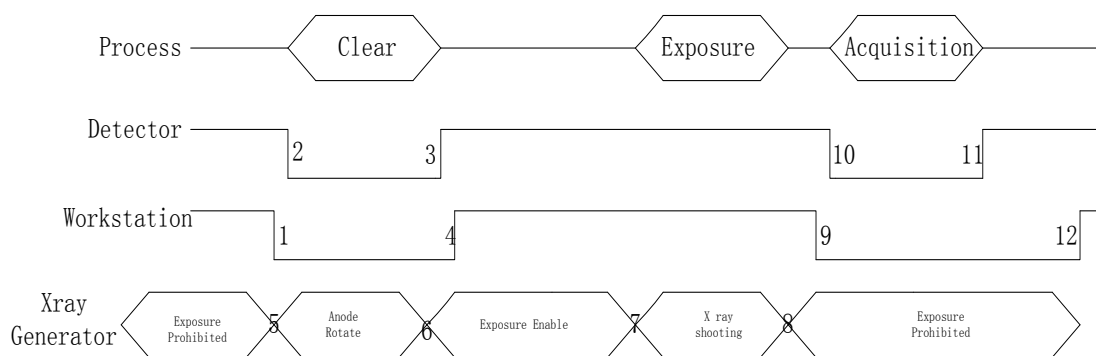

1. Workstation receives “prep” request, send command “Clear” to panel.
2. Panel receives “clear” from workstation, starts clearing leakage of panel. Meanwhile, panel send a message to workstation “Exposure Prohibited”.
3. Panel finishes “Clear” and send a message to workstation “Exposure Enable”.
4. Workstation shows “Exposure Enable” on the iDetector’s message bar to tell user shoot X ray now.
5. User triggers x ray generator to initialize and do anode rotation to prepare for X ray shooting.
6. X ray generator finishes preparation for X ray shooting and reminds user to shoot.
7. X ray generator starts releasing x ray

8. X ray generator finishes x ray shooting.
9. Workstation receives “Acquire” request, send command “Data Acquisition” to panel.
10. Panel receives “Data Acquisition” from workstation, start data acquisition operation.
11. Panel completes image acquisition and begins to send data to workstation.
12. Workstation receives all image data from panel which are after calibration if Hardware calibration is on.

4.1.2. Inner2 Mode

4.1.2.1. Block Diagram



Workstation is a host PC device installed with iDetector and SDK. Chapter 3 has described how to establish connection between panels and workstation. In inner2 mode, workstation does not control x ray generator. Users would decide when to shoot x ray.

4.1.2.2. Work Flow

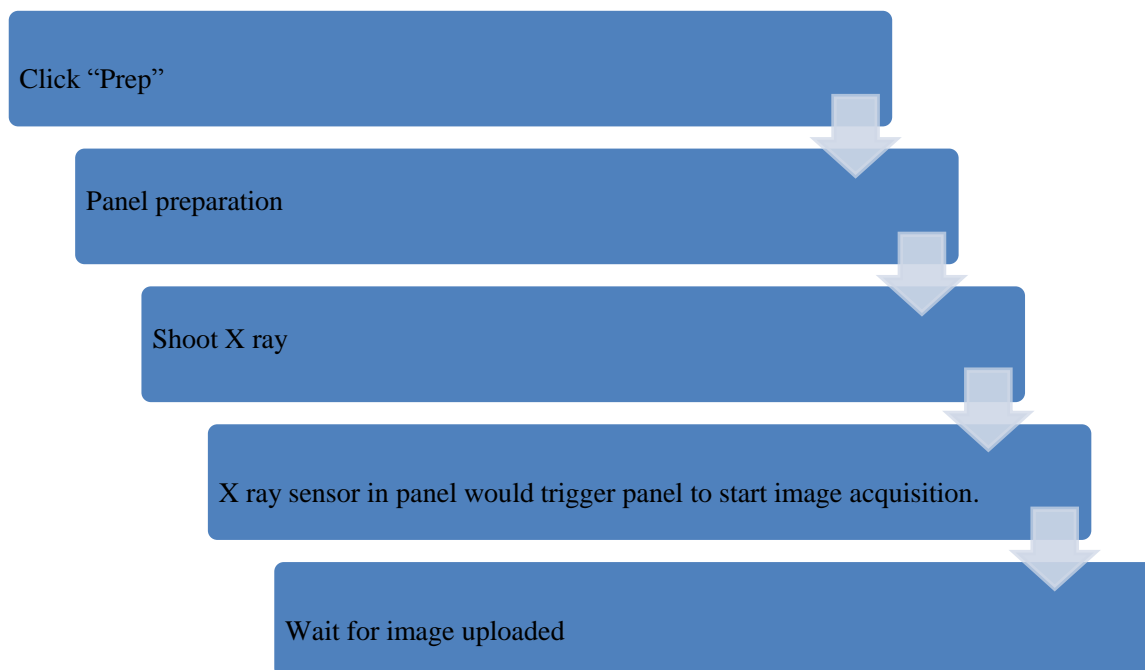

4.1.2.3. Timing Setting

To set a clear scenario for program, see diagram below for details

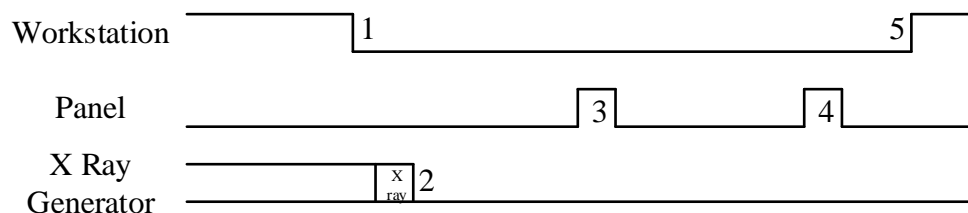

1. Workstation receives “prep” request.
2. X ray generator is ready for X ray shooting and begins to release X ray.
3. Panel starts uploading Pre-dark image and Light image to Workstation for preview. If hardware offset is selected, panel would do offset first, and then upload preview image.
4. Panel starts uploading Post-dark image to Workstation. If hardware offset is chosen, panel would do correction and calibration first, then upload processed image to Workstation.
5. Workstation into exposure prohibit state.

4.1.3. Freesync Mode

4.1.3.1. Block Diagram



Workstation is a host PC device installed with iDetector and SDK. Chapter 3 has described how to establish connection between panel and Workstation. In FreeSync mode, User doesn't interact with Workstation. After shooting, images would be shown on screen immediately.

4.1.3.2. Work Flow

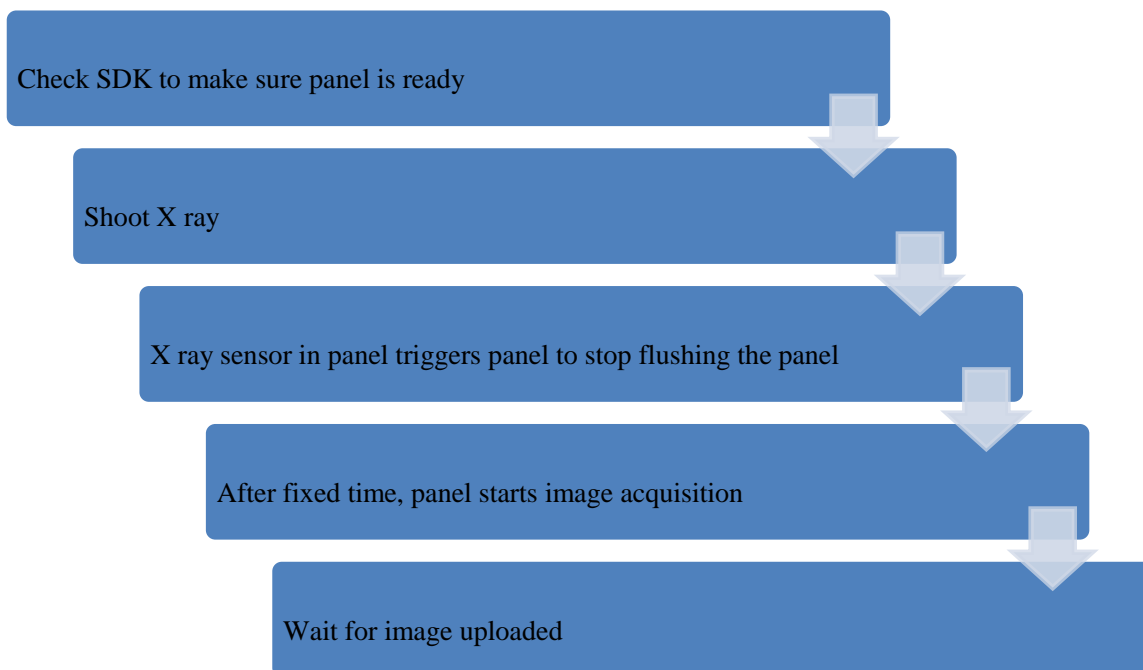

4.1.3.3. Timing Setting

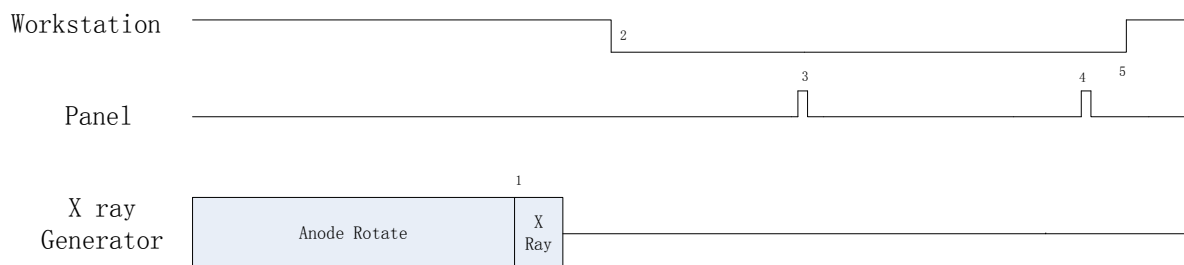

1. X ray generator is ready for X ray shooting and begins to release X ray.
2. Workstation receives “Exposure Prohibited” from Panel.
3. Panel starts uploading Pre-dark image and Light image to Workstation for preview. If hardware offset is selected, panel would do offset first, and then upload preview image.
4. Panel starts uploading Post-dark image to Workstation. If hardware offset is chosen, panel would do correction and calibration first, then upload processed image to Workstation.
5. Workstation receives “Exposure Enable” from Panel.

4.2. Connection Build

<p>Open SDK and choose product start connection</p>	
<p>Confirm the IP address and the Port are the same as the value in config.ini. The port should use the default value of 28000</p>	<pre> [System] Cfg_DetectorImp=E4W.d11 Cfg_ConnImp=ConnUdpTcp.d11 Cfg_CaliImp=CaliE4W.d11 Cfg_LogLevel=1 Cfg_UseServiceProcess=1 Cfg_ProtocolEdition=4 Cfg_ProductNo=32 Cfg_SN=KV07086025187 [Connection] Cfg_HostIP=192.168.8.188 Cfg_HostPort=28000 Cfg_ConnPort=1 Cfg_PleoraConnStr= Cfg_WinpcapConnStr= Cfg_RemoteIP=192.168.8.8 Cfg_RemotePort=27888 Cfg_PleoraPacketSize=0 Cfg_RepeatCmdEnable=0 [Calibration] Cfg_OffsetAlarmMinute=30 Cfg_GainAlarmTime=4 Cfg_DefectAlarmTime=12 Cfg_CaliValidity_PreWarnMinute=10 </pre>

Note: 1. once changing connection from different network card, user must re-connect panel with different IP address.

2. The rule of Multi-Share control is based on IP address. The second terminal with different IP address is not allowed to operate panel after the first one connected. If there is no command transmission between panel and Workstation over 5 minutes, panel releases access authority.

4.3. Panel Configuration

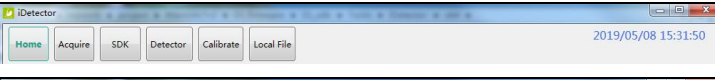
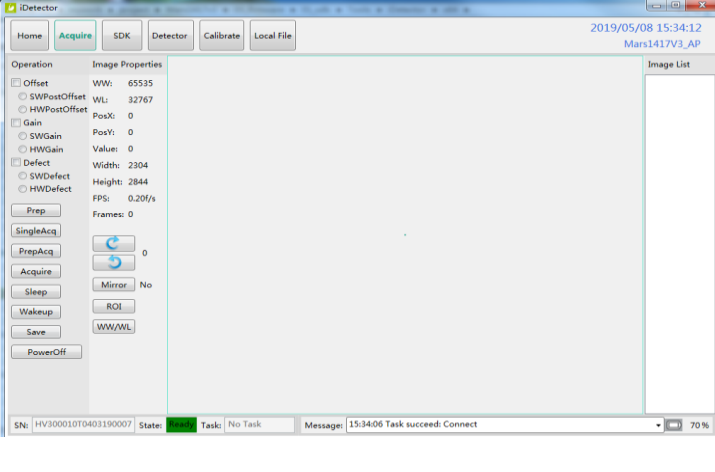
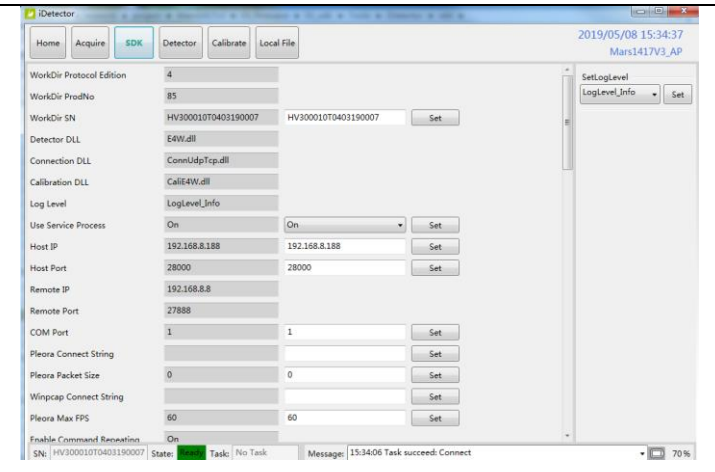
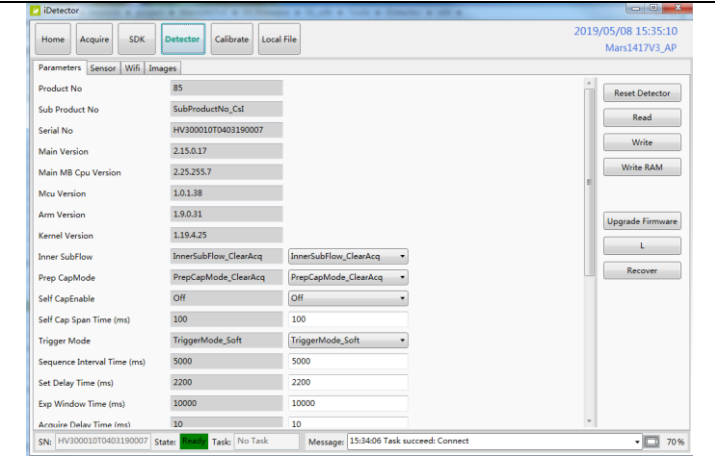
<p>Choose iDetector menu related modules</p>	
<p>Acquire module related setting, such as loading correction and calibration template, acquiring images</p>	
<p>SDK module related setting, such as IP address</p>	
<p>Detector module related setting, such as trigger module, wireless signal</p>	

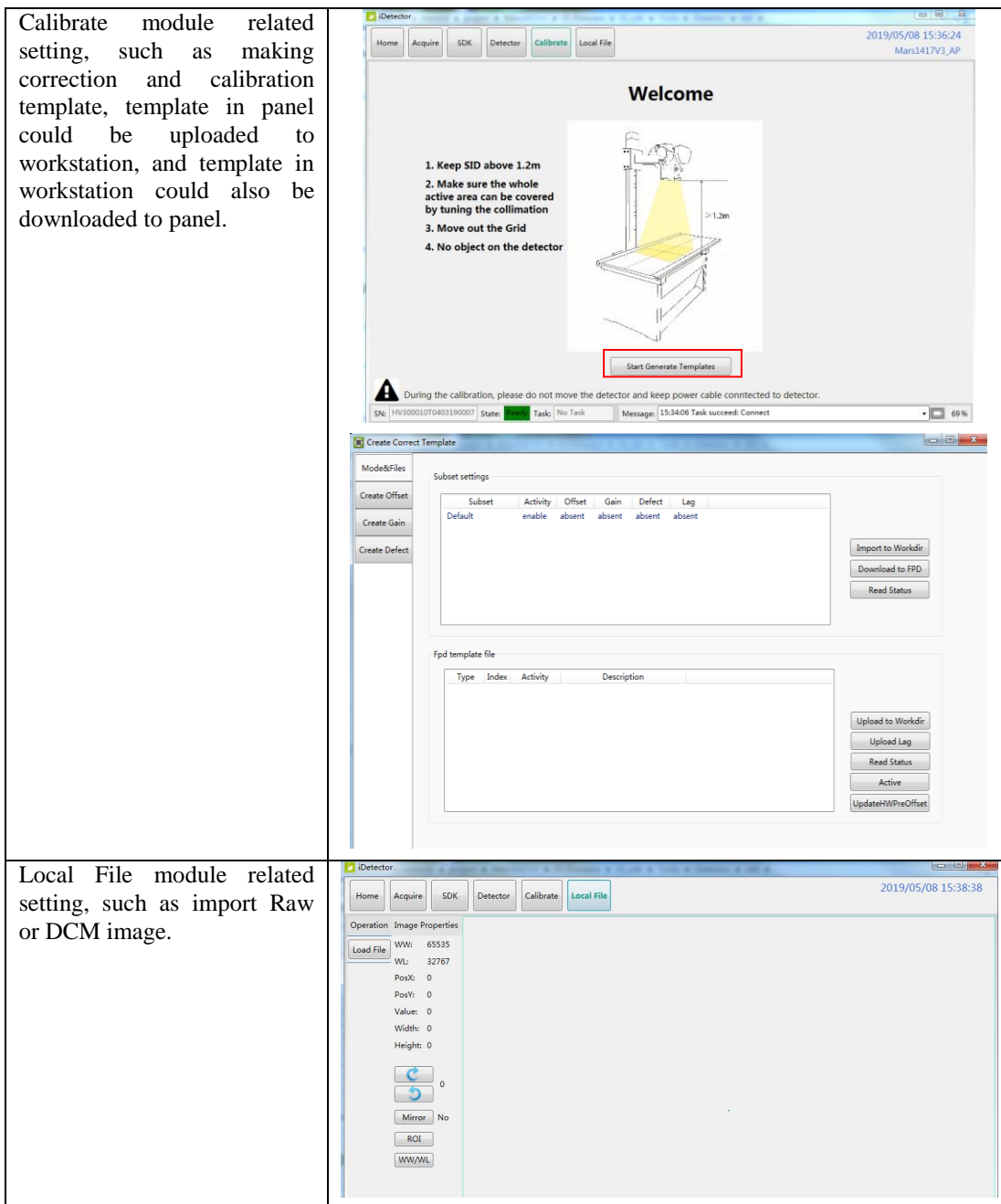

4.4. Correction and Calibration Template Generation

The correction and calibration should be performed after installation and it is recommended to perform the new correction and calibration after any major change on the system settings and hardware configuration. On the other hand, it is also recommended to do the correction and calibration in each 6 months.

4.4.1. Pre-offset Template Generation

If panel is configured to do Pre-offset correction, Pre-offset Template is necessary. See below

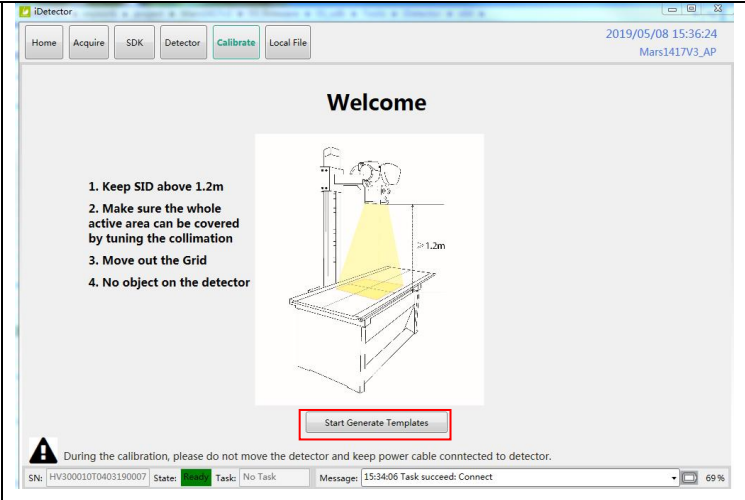
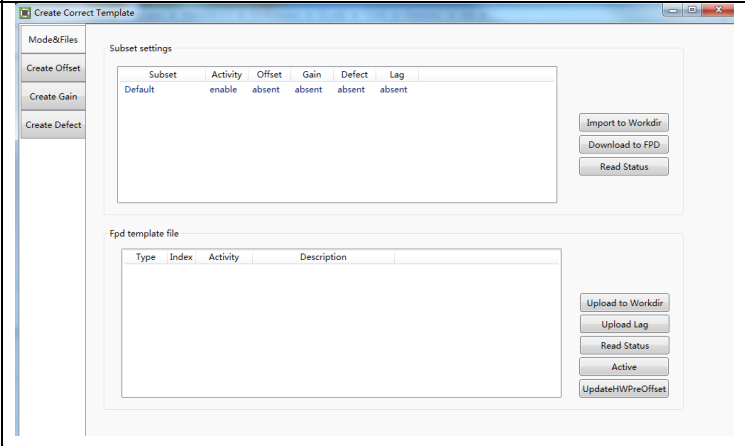
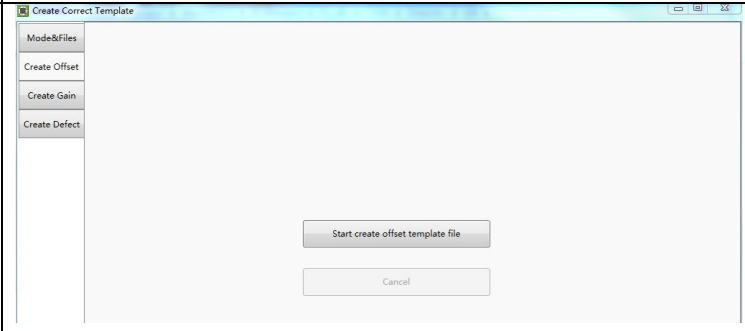
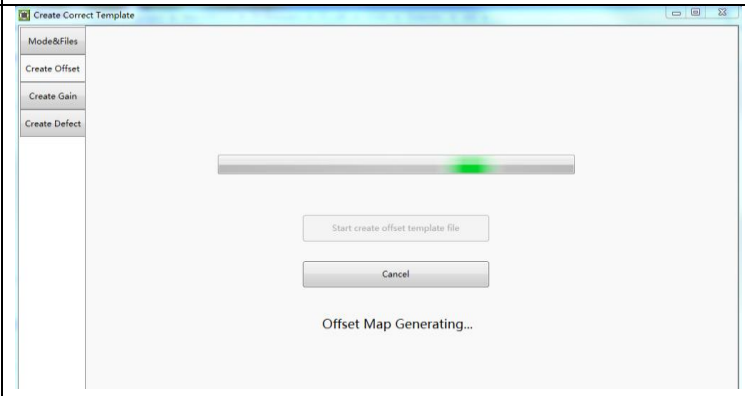
<p>Select "Calibrate"</p> <p>Click "Start Generate Templates"</p>	
<p>Click "Create Offset"</p>	
<p>Click "Start create offset template file"</p>	
<p>It will show "Offset Map Generating"</p>	

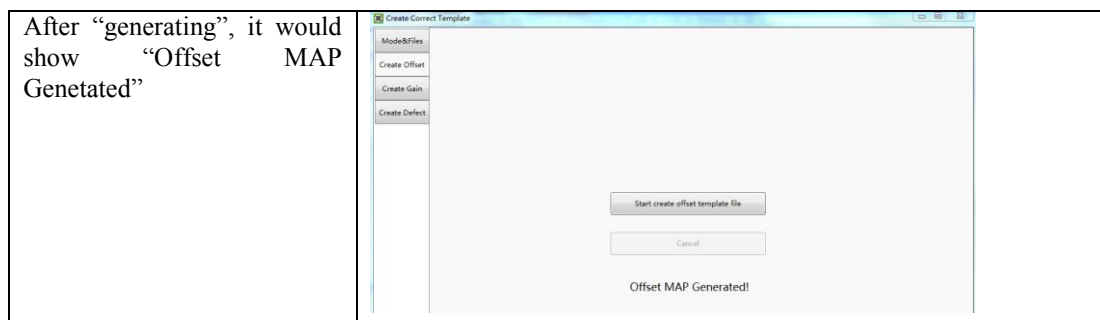

4.4.2. Gain Calibration Template Generation

Before Gain template generating, make sure SID1.2m, no copper is required, the GUI of the software maybe different with the below figures.

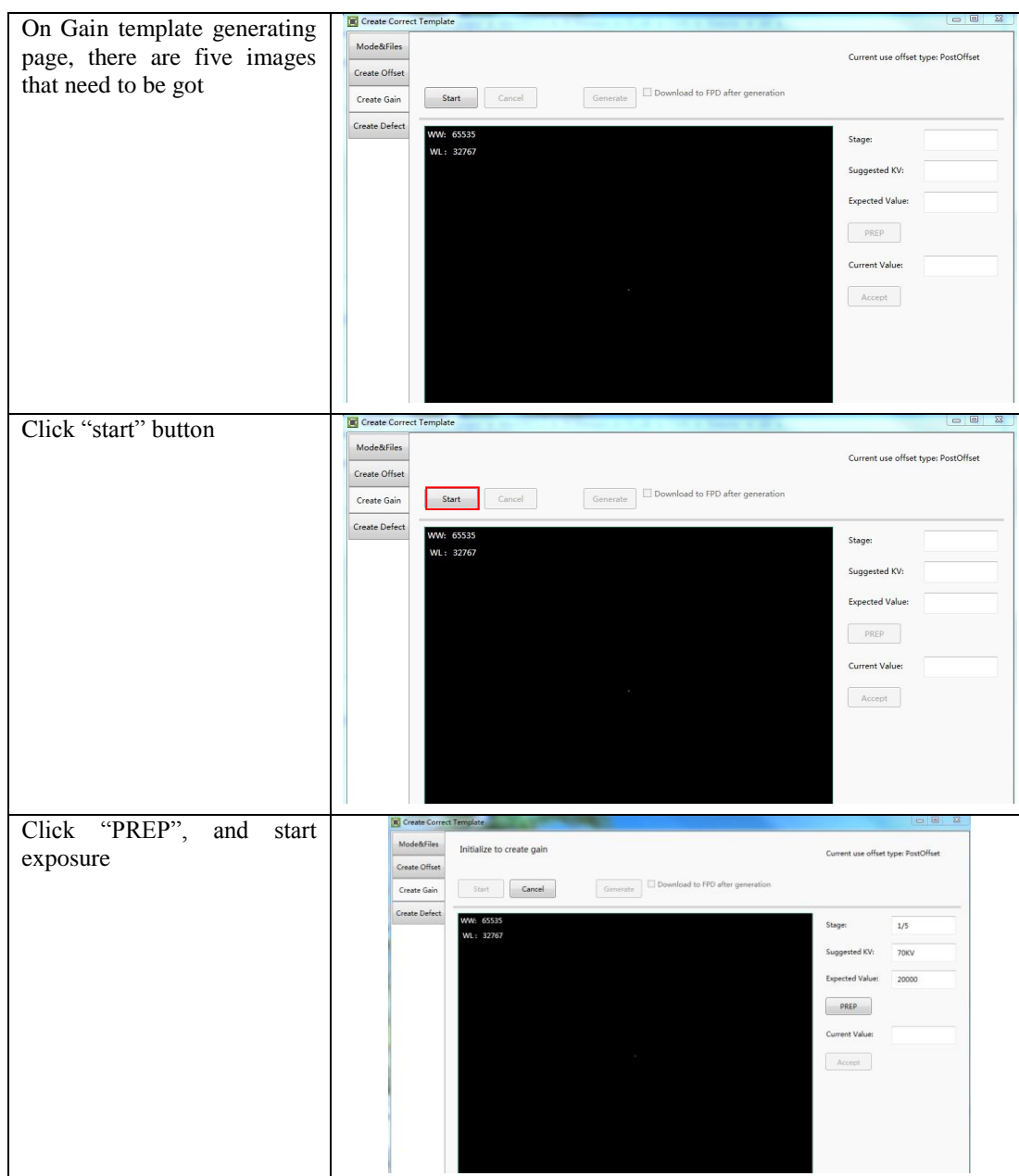

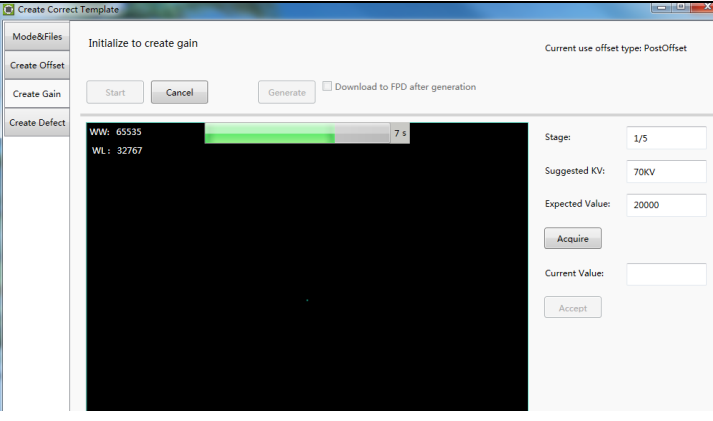
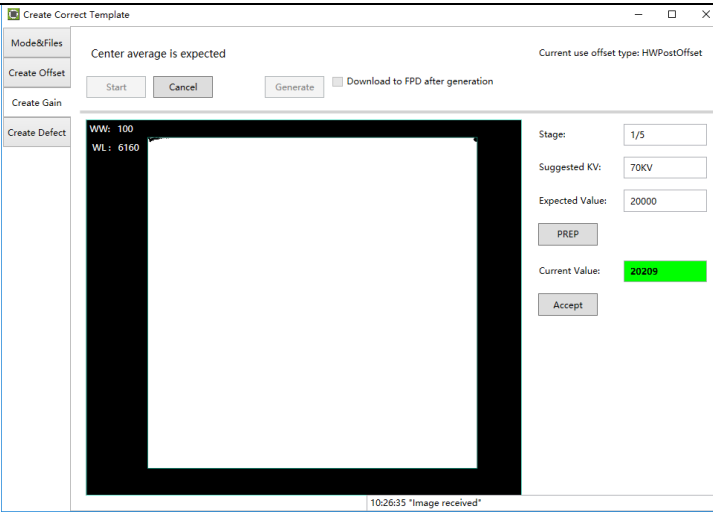
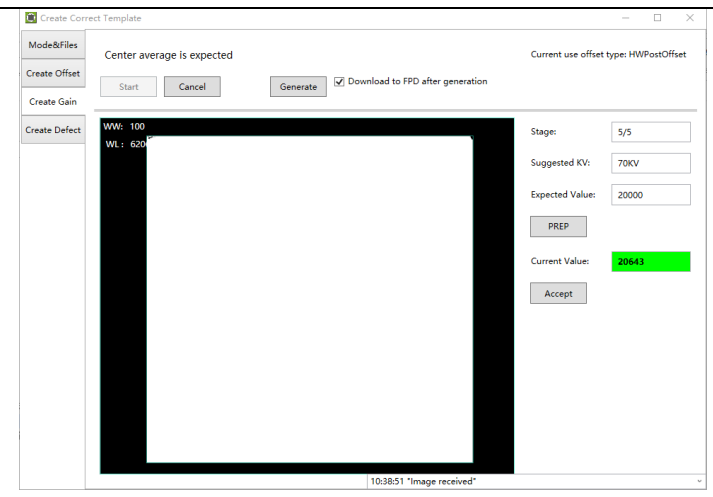
<p>After exposure, click “Acquire” to get the light image</p>	
<p>If the value meet the expected value, click “Accept”, then get the other four images. If the value does not meet the expected value, please do not click the “Accept”, and adjust the exposure dose ,then click the “PREP” to get light image again</p>	
<p>After getting five images, click “Generate” to generate gain template</p>	

Notes: 1 please use software post offset correction.

4.4.3. Defect Correction Template Generation

Before Defect template generating, make sure SID1.2m, no copper is required, the GUI of software maybe different with the below figures.

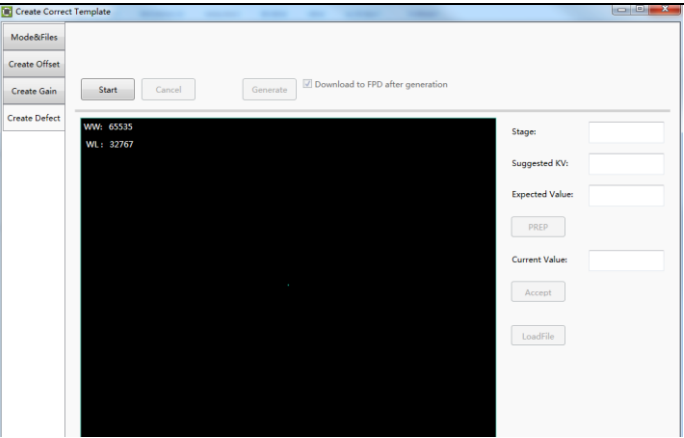
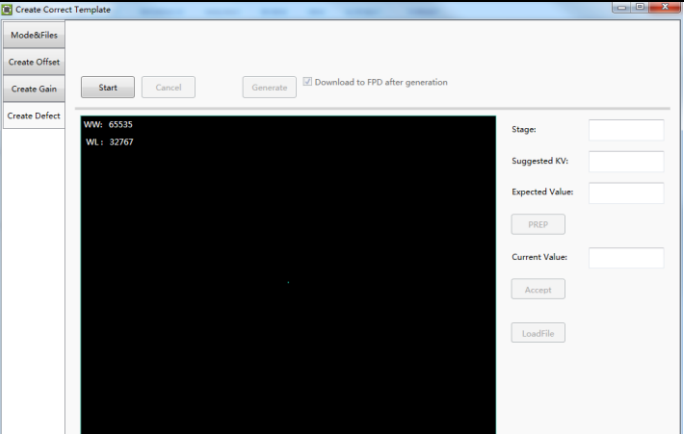
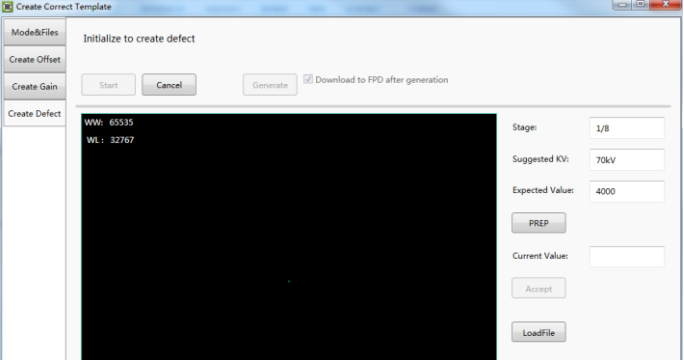
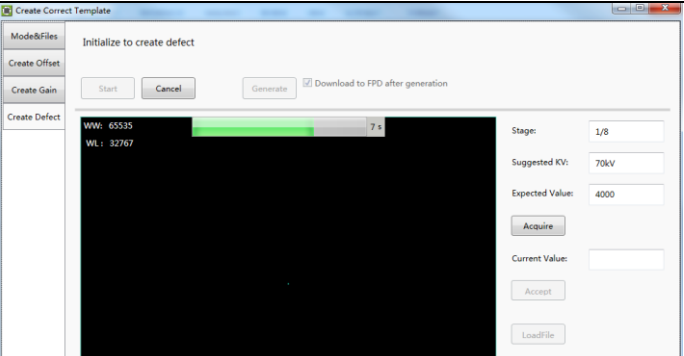
<p>On the “Defect Calibration” page, start exposure, there are 8 images need to be captured.</p>	
<p>Click “Start” button</p>	
<p>Click “PREP”, and start exposure</p>	
<p>After exposure, click “Acquire” to get the light image</p>	

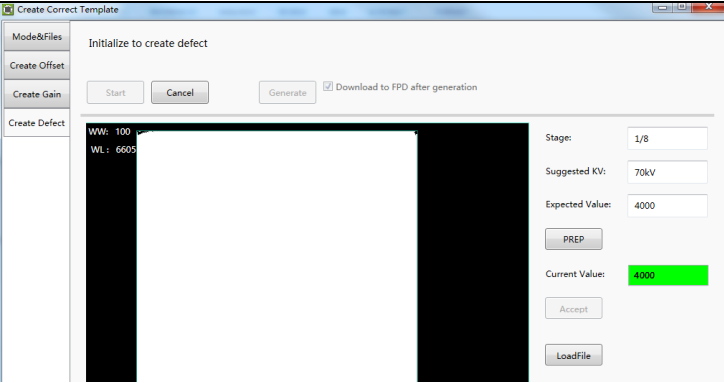
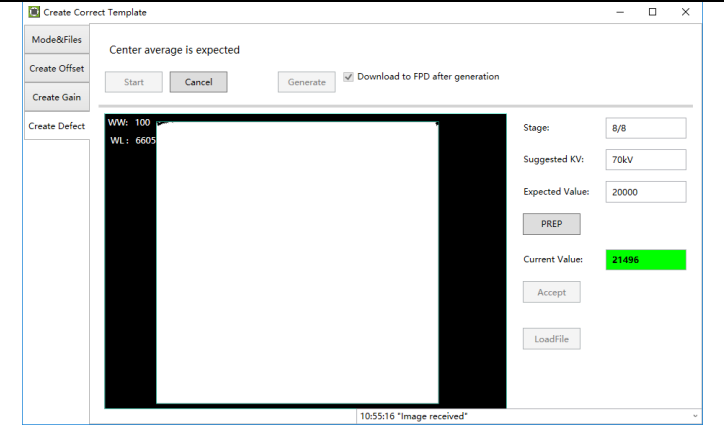
<p>If the value meet the expected value, click “Accept”, then get the other 7 images.</p> <p>If the value does not meet the expected value, please do not click the “Accept”, and adjust the exposure dose ,then click the “PREP” to get light image again</p>	
<p>After getting 8 images, click “Generate” to generate gain template</p>	

Note: 1 please use software post offset mode.

2. Make sure your x ray dose is right, if your dose is out of the range, iDetector will remind you to adjust the dose. Then you can click “start creating” and try again.
3. If users operate with two panels, SDK has a probability of quit automatically.

4.5. Image Check and upload

“OPEN” provides two features for image check and uploading. Local Image Check, Panel Image Upload. Local Image Check defines function to check image saved in Workstation. Panel Image Upload defines function to upload images stored in panel.

4.5.1. Local Image Check

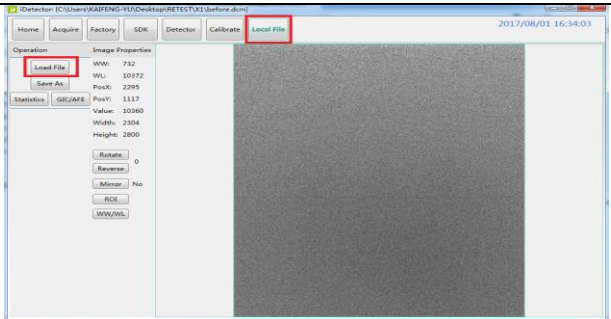
<p>Click “Local File” button in “Local File” UI, choose the specified file</p>	
<p>Choose images stored in /</p>	

Workstation, images would be shown on screen

4.5.2. Panel Image Upload

Make sure firewall is closed

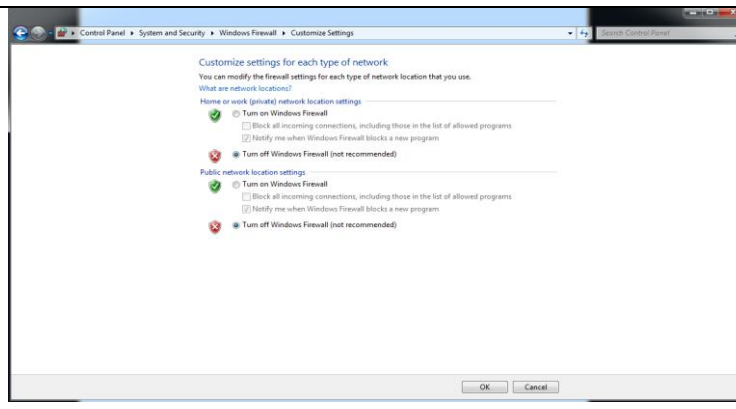

Panel Image is uploaded as following.

Click “Image” page in “Detector” UI

Click “Query Images” button and the list will be showed which are stored in the detector

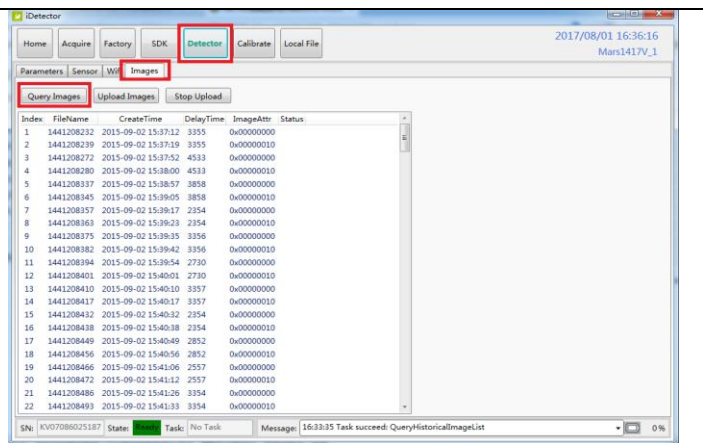

Click “Upload Images”: choose the specified image, and click “OK”, after the state changed to “success” which means that the image has been uploaded

User can cancel the process of uploading if click “Stop Upload”

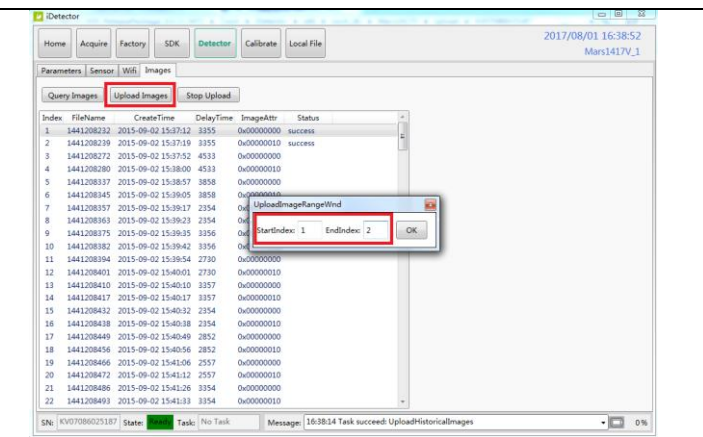

The uploaded images are saved under the path of the detector SN

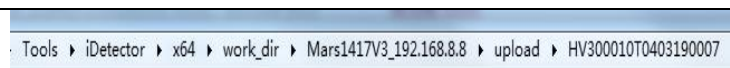

4.6. Defect Template Check and Modification

iDetector provides function to check defect template. If defect template has updates, user could add and delete defect pixel or defect lines by modifying defect template opened.

4.6.1. Defect Template Check

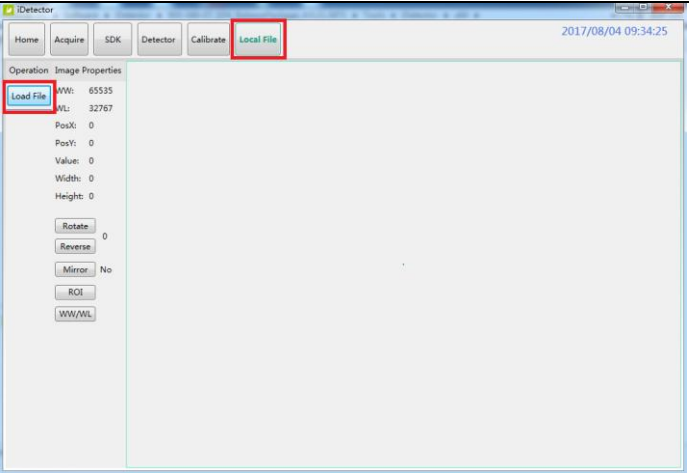
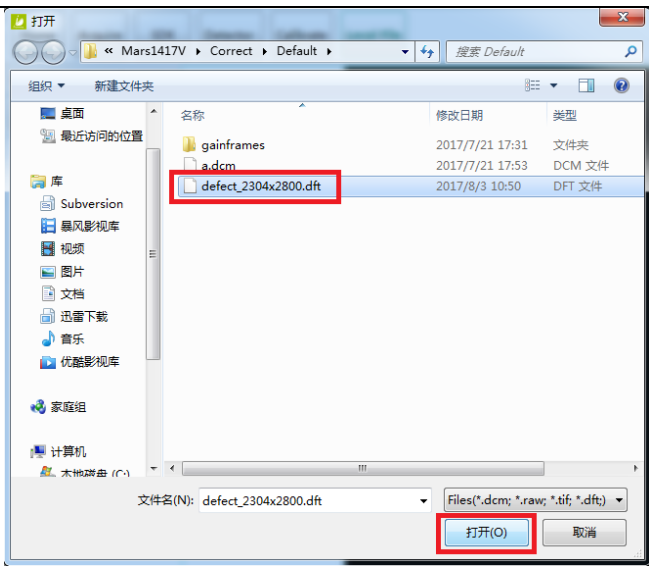
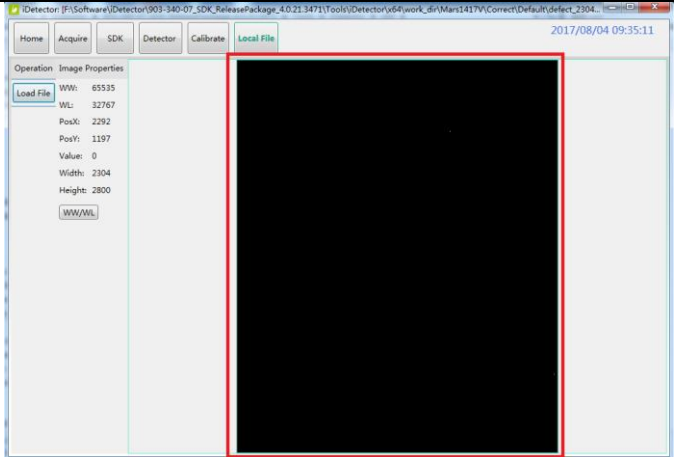
<p>Click “LoadFile” on “LocalFile” page</p>	
<p>Choose the specified defect template, and click “Open”</p>	
<p>The defect template will showed on the UI</p>	

4.6.2. Defect Template Modification

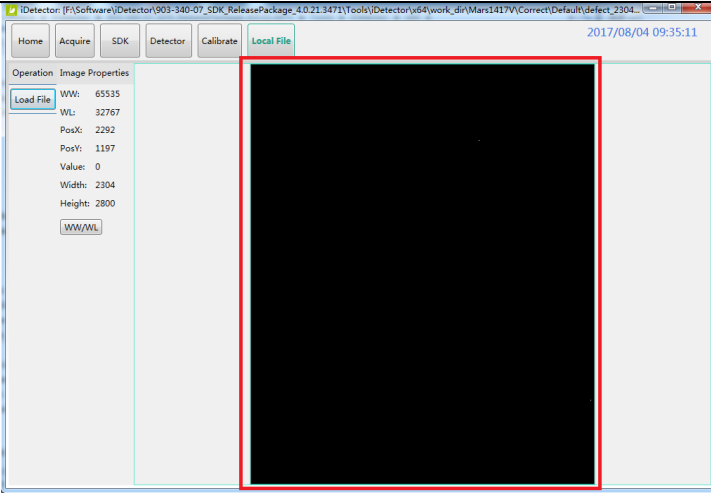
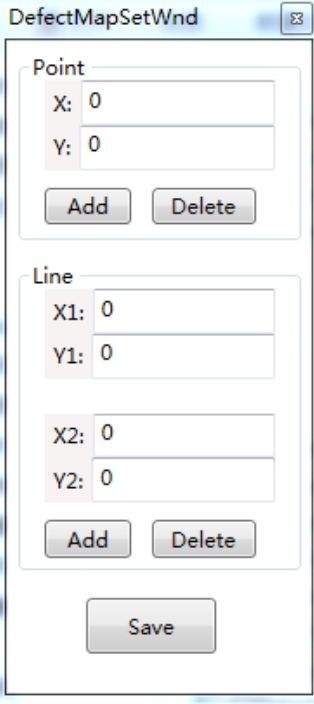
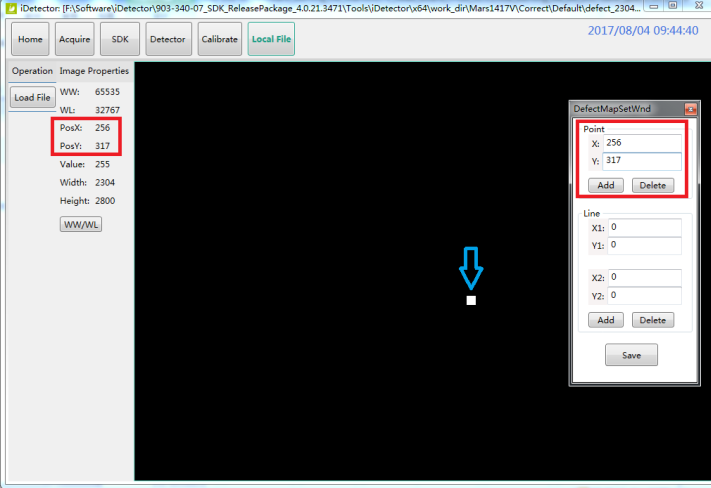
<p>Open the specified defect template</p>	
<p>The defect management dialog box will be showed</p>	
<p>Find the pixel that needs to be managed, type the coordinate of the pixel and click “Add”, the information will be added to the template If click “Delete”, the information will be deleted Click “Save”</p>	

It is similar to manage the defect pixel, If user need to add the defect line, type the coordinate of the line and click “Add”

If the information needs to be deleted, click “Delete”

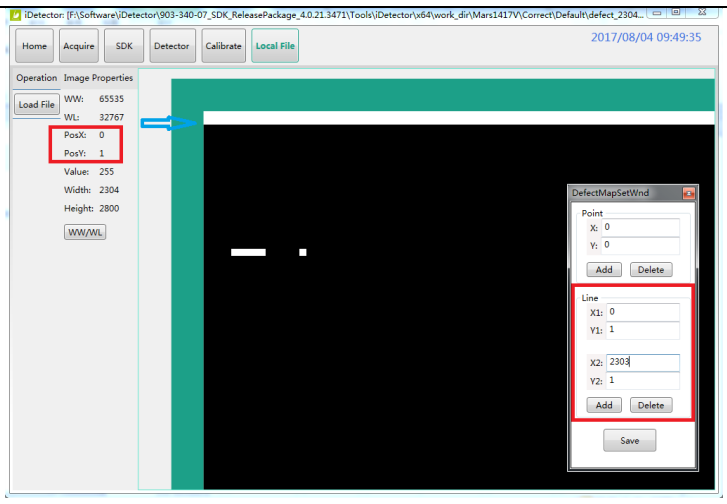

4.7. Correction and Calibration Management

4.7.1. Correction and Calibration template synchronization

Panel supports correction and calibration template storage. So template in panel could be uploaded to Workstation, and template in Workstation could also be downloaded to panel.

After generating the offset ,gain and defect templates, select the templates and click “Download to FPD”

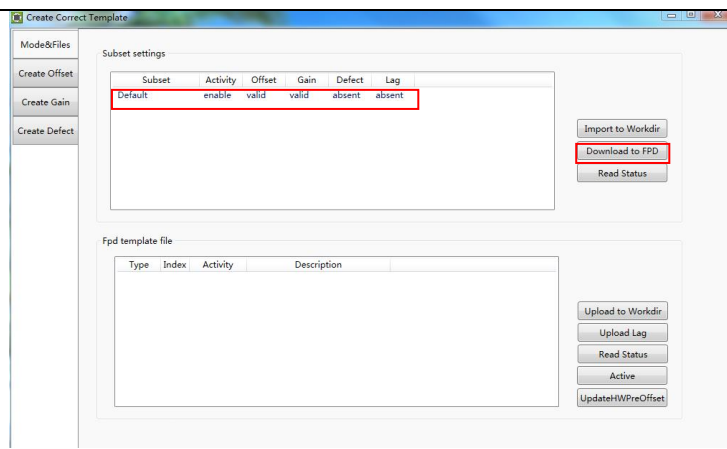

Click “DownLoad”

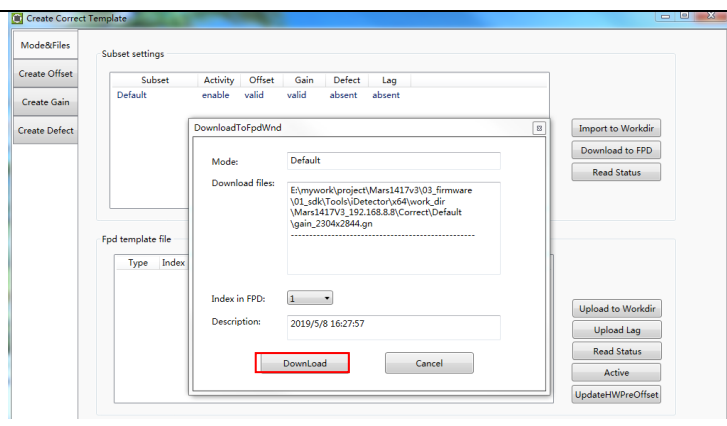

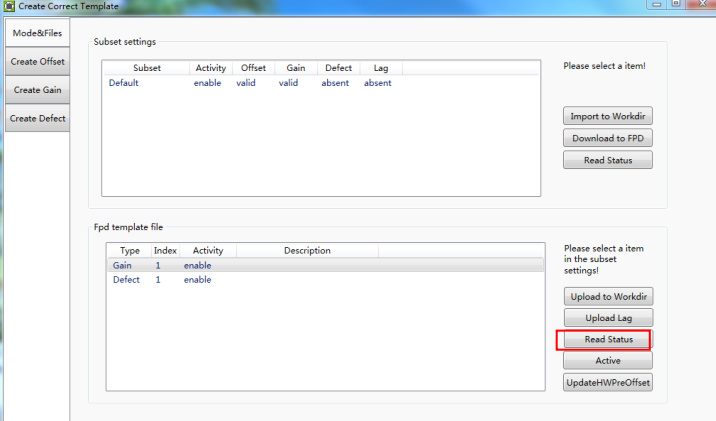
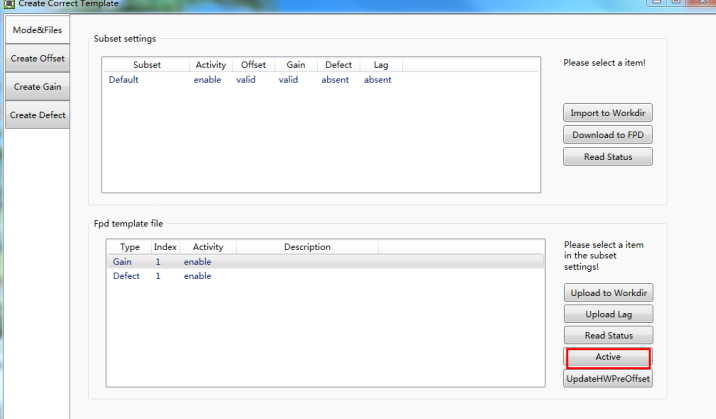
<p>Click "Read Status"</p>	
<p>If the activity shows disenable, please select the one and click "Active" to enable it</p>	

4.7.2. Correction and Calibration management

Panel supports two ways to do correction and calibration. Software Correction and Calibration defines the scenario that Workstation completes all correction and calibration. If panel complete all correction and calibration by itself, it is named as Hardware Correction and Calibration.

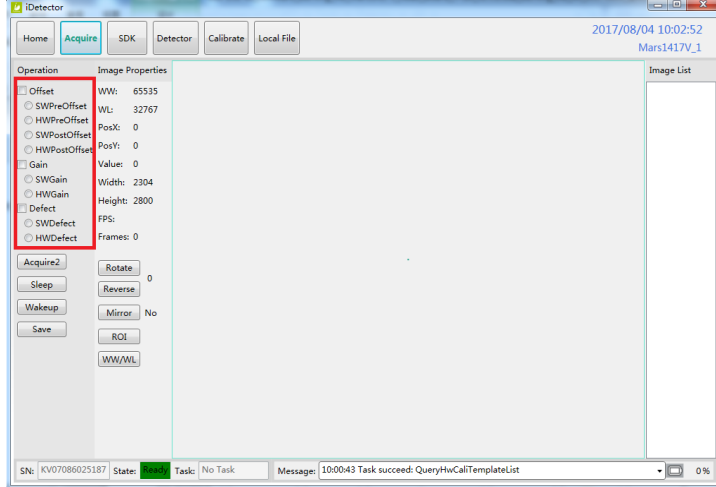
<p>User can set the calibration method on "Acquire" page</p>	
--	--

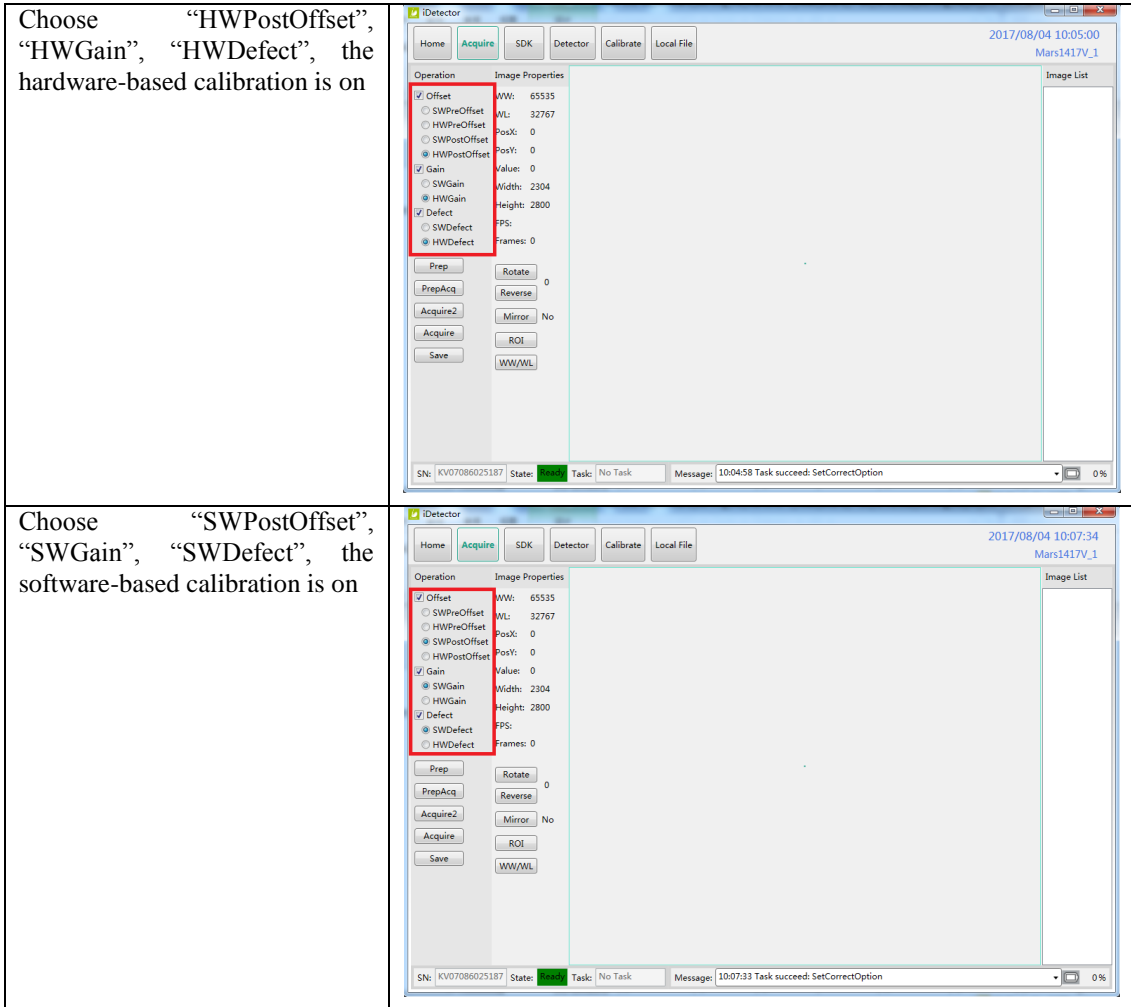



4.8. Firmware Update

Panel supports the use of the Web way to upgrade the firmware, if a user needs to update the firmware, please complete the following steps.

Before update, please make sure that the battery capacity is more than 80% or the DC power is connected.

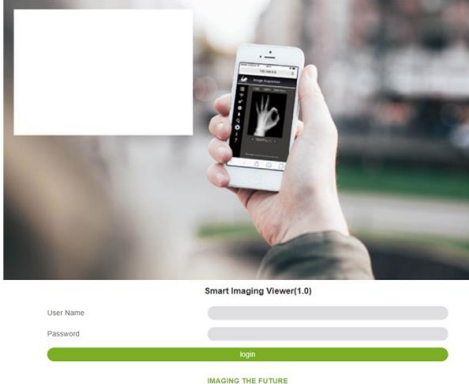
4.8.1. MCU Update

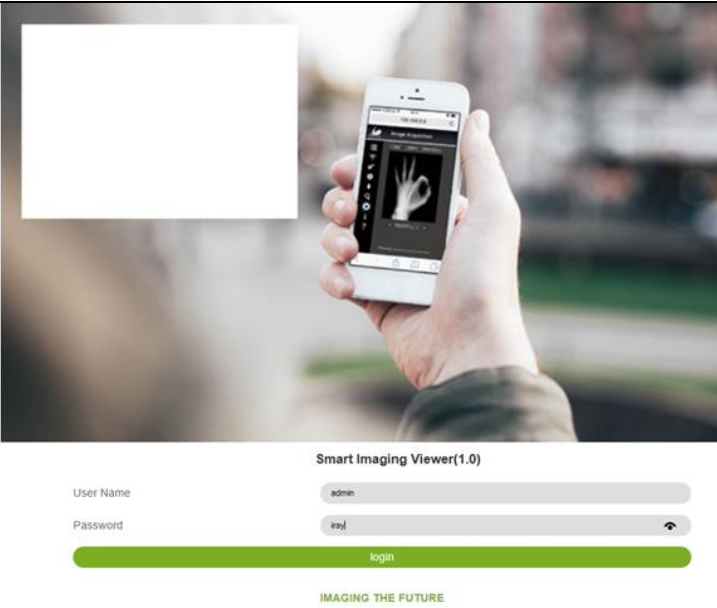

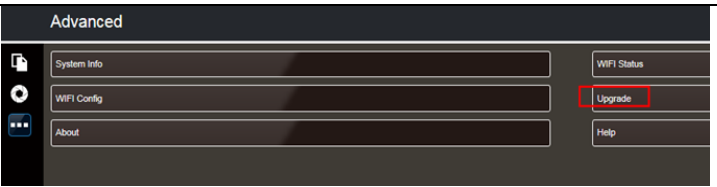
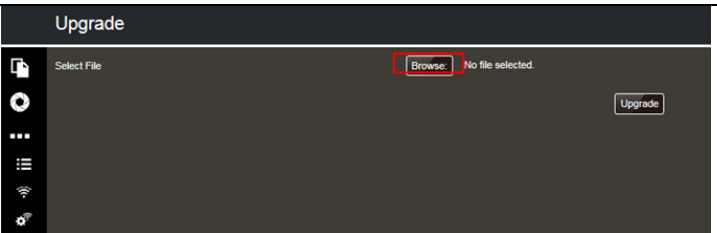
<p>Connect the panel to PC</p>	<p>/</p>
<p>Open a browser, and type “192.168.8.8” in the search bar, then click the “Enter” button</p>	

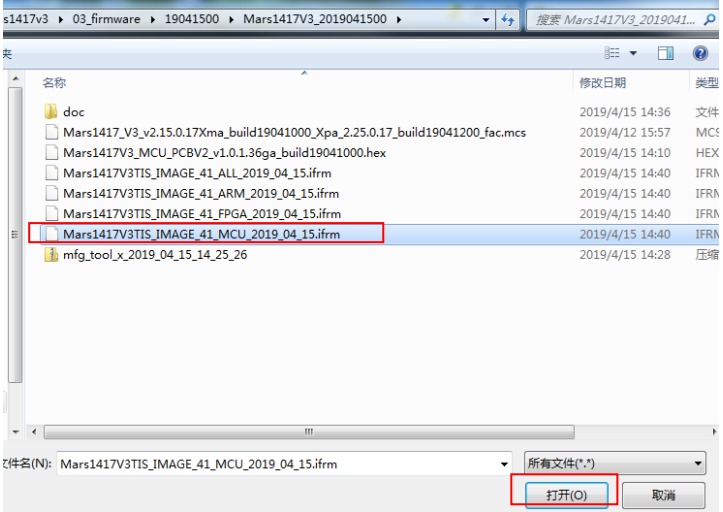
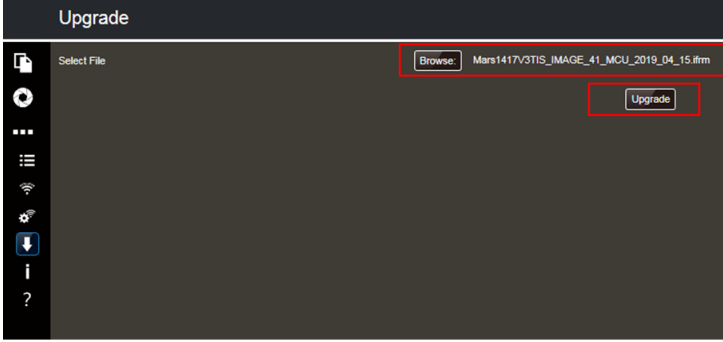
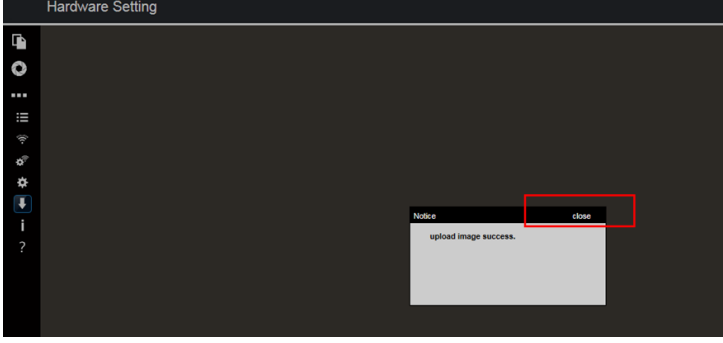
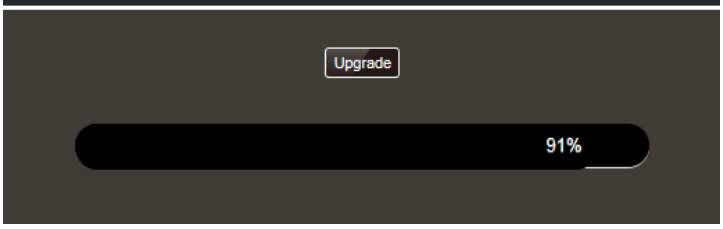
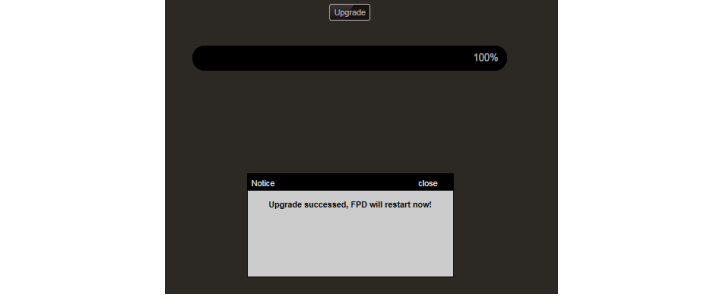
<p>User name: admin Password: iray Click “login”</p>	 <p>The screenshot shows the login interface for 'Smart Imaging Viewer(1.0)'. It features a header with the title and a green 'login' button. Below the button are input fields for 'User Name' (containing 'admin') and 'Password' (containing 'iray'). A green bar at the bottom contains the slogan 'IMAGING THE FUTURE'. The background image shows a hand holding a smartphone displaying a hand X-ray.</p>
<p>Click “”</p>	 <p>The screenshot shows the 'Getting Image' screen. It features a large X-ray image of a hand. On the left side, there is a vertical menu with three icons: a folder, a gear, and three dots. The three dots icon is highlighted with a red box. At the bottom right of the X-ray image, there is a button labeled '(Back to Image List)'. The title 'Getting Image' is at the top right.</p>
<p>Click “Upgrade”</p>	 <p>The screenshot shows the 'Advanced' settings screen. It has a dark background with a vertical menu on the left containing icons for a folder, gear, three dots, and a list. The main area contains four rows: 'System Info', 'WiFi Config', 'About', and 'WiFi Status'. The 'Upgrade' button in the 'WiFi Config' row is highlighted with a red box. The 'WiFi Status' and 'Help' buttons are also visible.</p>
<p>Click “Browse”</p>	 <p>The screenshot shows the 'Upgrade' screen. It features a 'Select File' section with a 'Browse' button highlighted in red. To the right of the 'Browse' button, it says 'No file selected.'. An 'Upgrade' button is located at the bottom right. The vertical menu on the left is consistent with the previous screens.</p>

<p>Find the MCU file, select it and open it</p>	
<p>The selected file name will be displayed on the interface. Click “Upgrade”</p>	
<p>Click “close”</p>	
<p>There will show the progress bar.</p>	
<p>If upgrade success, the interface as shown in the picture on the right will be displayed. Otherwise, it means failure.</p>	

4.8.2. FPGA Update

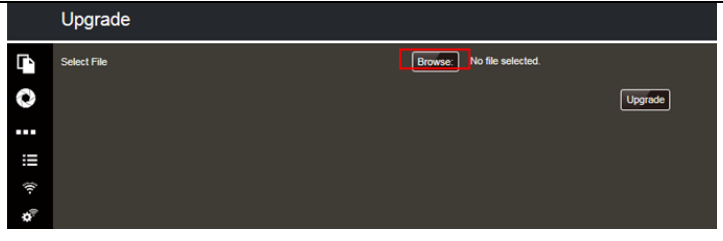
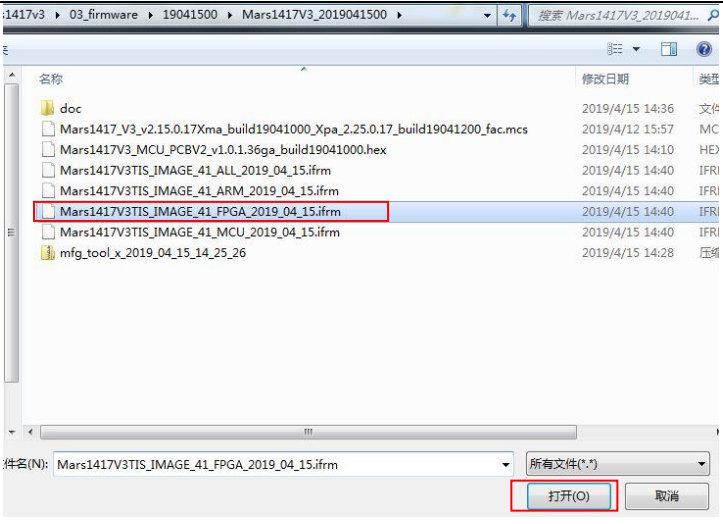

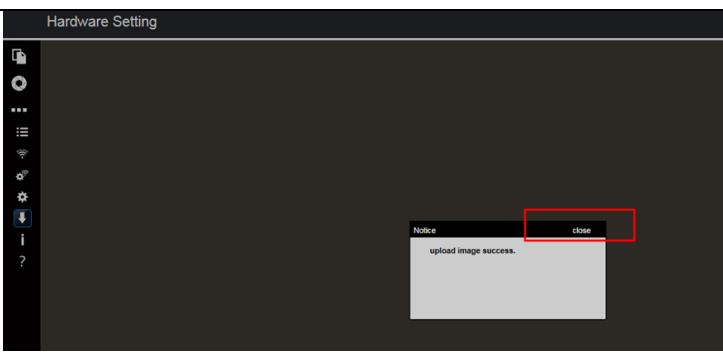
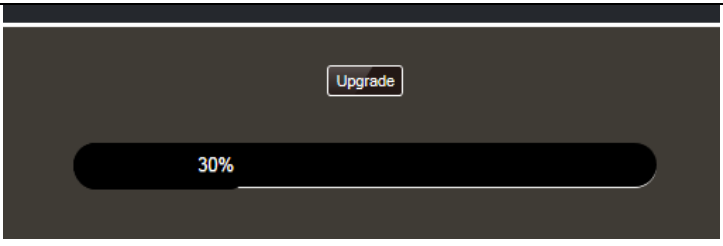
<p>Connect the panel to PC</p>	<p>/</p>
<p>Open a browser, and type "192.168.8.8" in the search bar, then click the "Enter" button</p>	
<p>User name: admin Password: iray Click "login"</p>	
<p>Click "☰"</p>	
<p>Click "Upgrade"</p>	

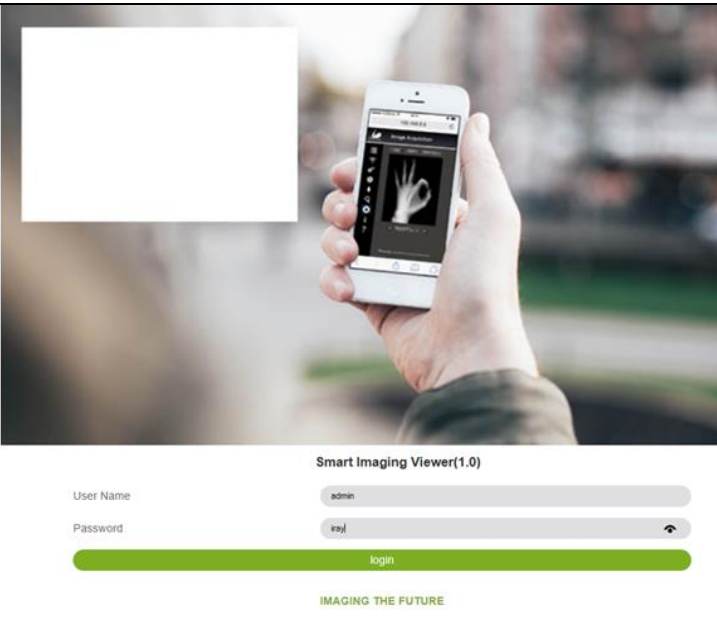
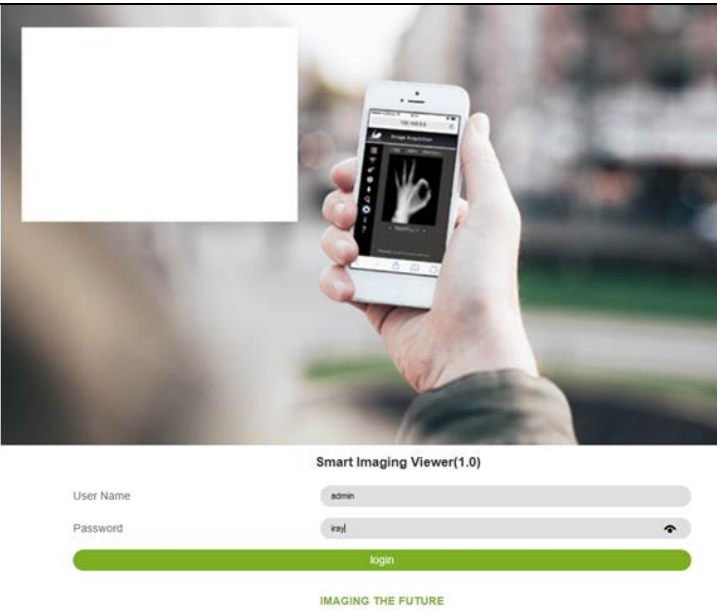

<p>Click “Browse”</p>	
<p>Find the FPGA file, select it and open it</p>	
<p>The selected file name will be displayed on the interface. Click “Upgrade”</p>	
<p>Click “close”</p>	
<p>There will show the progress bar.</p>	

<p>If upgrade success, the interface as shown in the picture on the right will be displayed. Otherwise, it means failure.</p>	
---	--

4.8.3. ARM Update

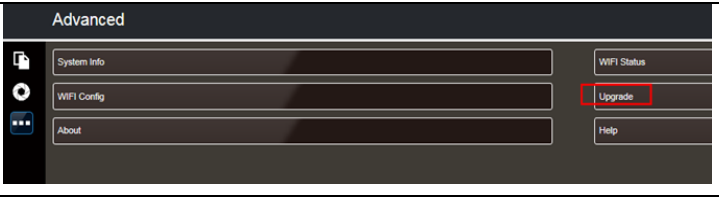
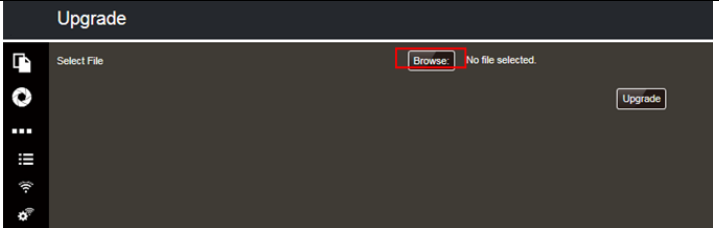
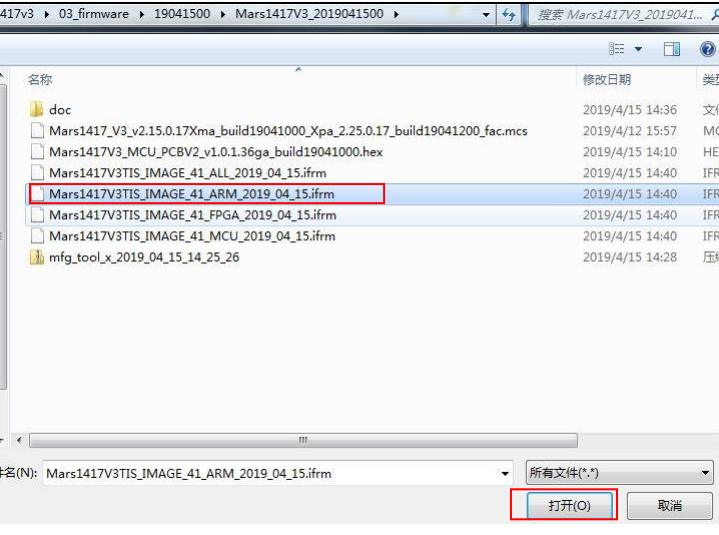
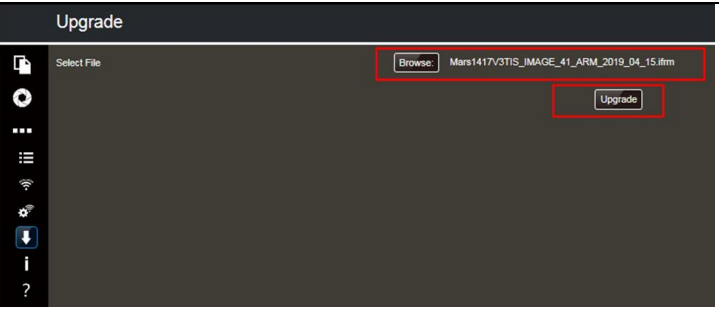
<p>Connect the panel to PC</p>	<p>/</p>
<p>Open a browser, and type “192.168.8.8” in the search bar, then click the “Enter” button</p>	
<p>User name: admin Password: iray Click “login”</p>	

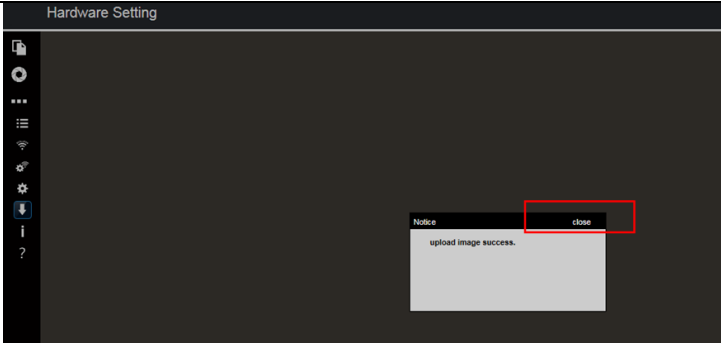
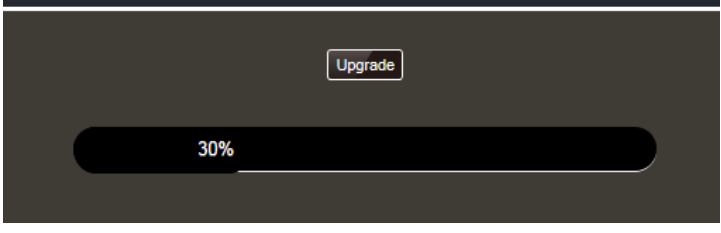
<p>Click “”</p>	
<p>Click “Upgrade”</p>	
<p>Click “Browse”</p>	
<p>Find the ARM file, select it and open it</p>	
<p>The selected file name will be displayed on the interface. Click “Upgrade”</p>	

Click “close”	
There will show the progress bar.	
If upgrade success, the interface as shown in the picture on the right will be displayed. Otherwise, it means failure.	

4.8.4. ALL FIRMWARE Update

All of the firmware (MCU, FPGA, and ARM) can be upgraded at the same time, if the file selected is like “Mars1417V3TIS_IMAGE_41_ALL_2019_04_15.ifm”. And the upgrade steps please refer the steps above.

4.9. Short cut

iDetector supports some shortcuts as follows:

- Double-click the left mouse button, the image displayed in center and with maximum size.
- Double-click the right mouse button, the window level and width adjusted to WL: 32767/WW: 65535.
- Drag the left mouse button, drag the image displayed.
- Lateral-drag the right mouse button to adjust the window width, and vertical-drag the right mouse button to adjust the window level.
- F3 Key: Quickly adjust the image window width and window level.

4.10. Software

4.10.1. Main GUI

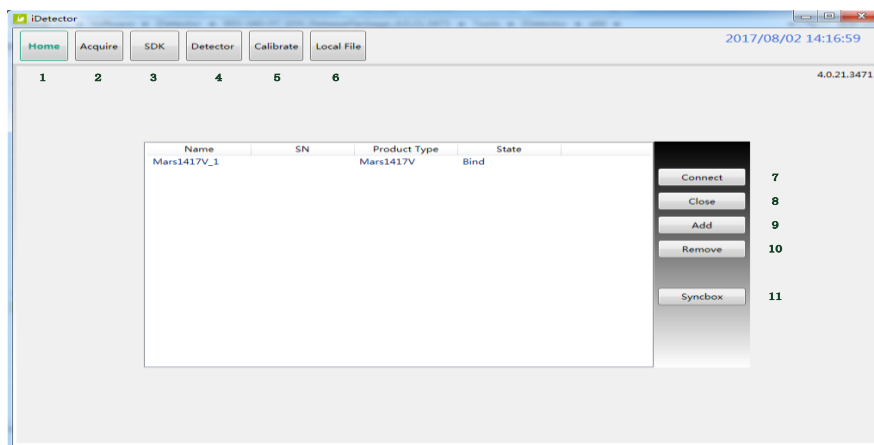

Our company provides test tools, such as iDetector for testing the basic performance of detector. It can connect the detector, acquire image, image correct and calibrate.

Function description of regions and buttons within the main window as follows:

1	Home	Home page, shows the list of the detectors
2	Acquire	Acquire images, free for use after connecting the detector
3	SDK	Configure UI for SDK, free for use after connecting the detector
4	Detector	Configure UI for detector, free for use after connecting the detector
5	Calibrate	Calibration UI, for generation and management of the calibration template
6	Local File	Image management, free for use at any time
7	Connect	Button for connecting the detector
8	Close	Button for disconnecting the detector
9	Add	Button for add the instance for one detector
10	Remove	Button for delete the instance for one detector
11	Syncbox	Management for syncbox

4.10.2. Message Box

4.10.2.1. Status Box

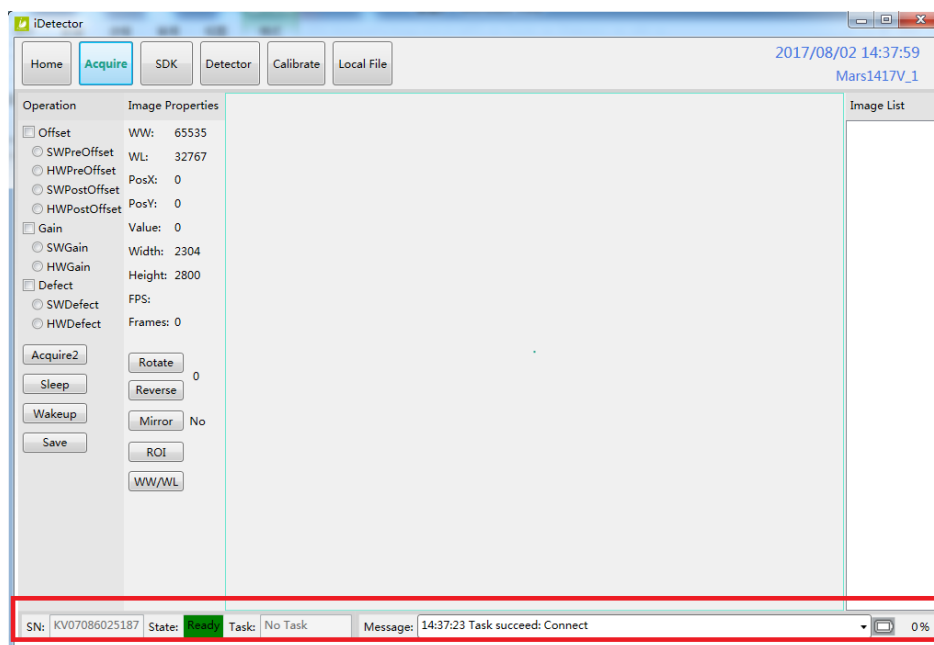

Status box defines the current status of panel.

SN	Serial Number of the detector
Status	Status of the detector, busy or ready
Task	The current task being executed
Message	Information
 0%	Remaining power of the battery, showed as percentage

4.10.2.2. Progress Bar

Progress Bar defines as following.



If progress bar is Green when shooting X ray, image quality is acceptable, otherwise image quality would degrade.

4.10.3. Configuration GUI

4.10.3.1. General Settings

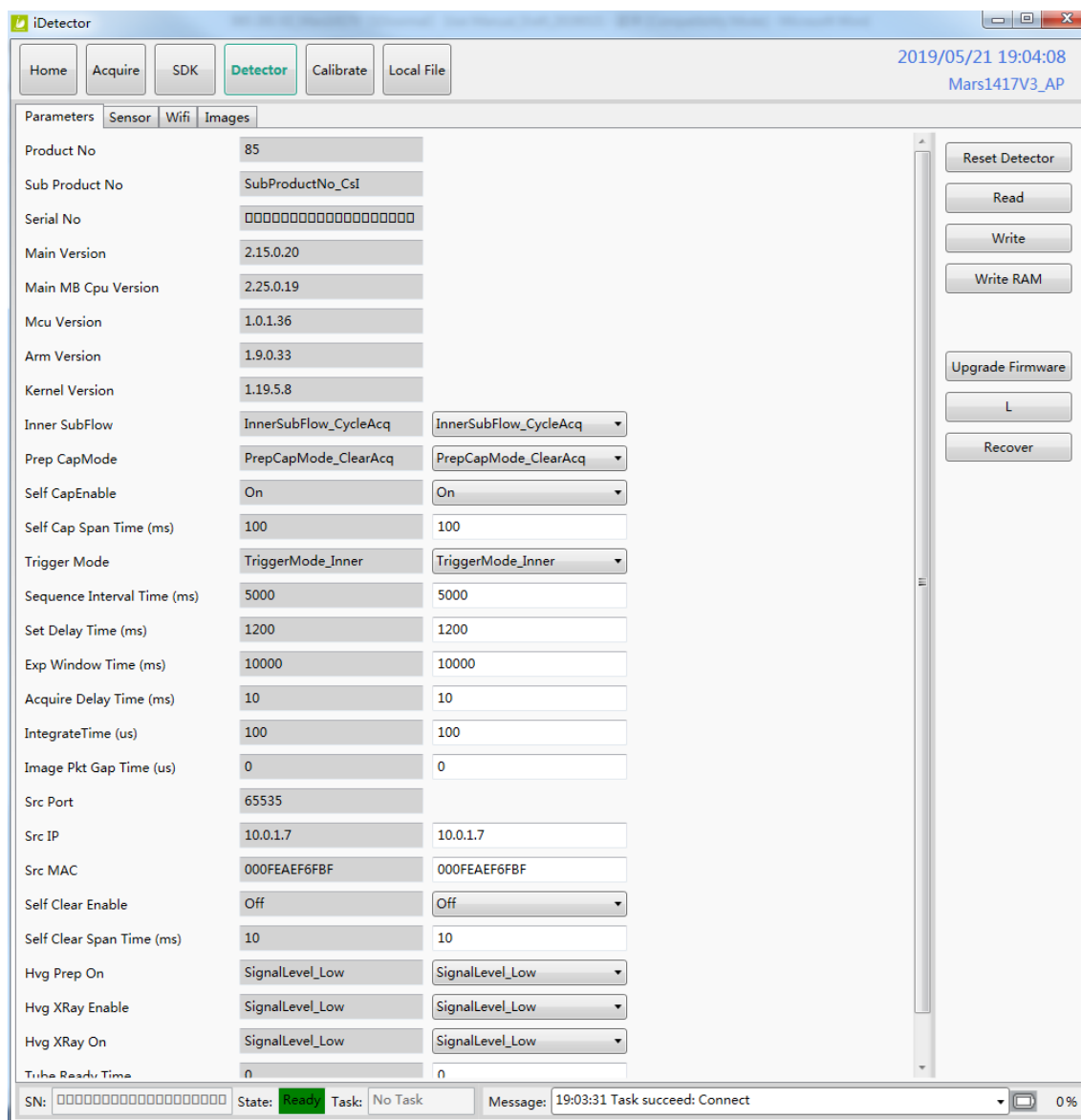

Except the following parameters, the value should not be modified for other parameters.

Description		Modify
Product No	Type number of the detector	NO
Sub Product No	Sub-type of the detector	NO
Serial No	Serial number of the panel	NO
Main Version	Version of the firmware of Main FPGA	NO
Main MB Cpu Version	Version of the MB Cpu of Main FPGA	NO
MCU Version	Version of the firmware of MCU	NO
Arm Version	Version of the App of ARM	NO
Kernel Version	Version of the Kernel of ARM	NO
Inner Subflow	Sub work-flow	Yes

Prep CapMode	Reserved	Yes
Self CapEnable	Reserved	YES
Self Cap Span Time	Should not be modified, and keep the original value	YES
Trigger Mode	Trigger mode	YES
Sequence Interval Time	Should not be modified, and keep the original value	YES
Set Delay Time	Exposure window for Freesync mode	YES
Exp Window Time	Exposure Window for Software/Inner mode, the value should not be large than 10s	YES
Acquire Delay Time	Reserved	YES
Integrate Time	Should not be modified, and keep the original value	YES
Src Port	Port number for detector	NO
Src IP	IP address for detector	YES
Src MAC	MAC address for detector	YES
Dest Port	Port number for PC	NO
Dest IP	IP address for detector	NO
Self Clear Enable	Related to Prep CapMode, the value should be configured as "On" if Prep CapMode is configured as PrepCapMode_ClearAcq, otherwise should be "Off" If the Trigger Mode is Software/Inner, the value should be "On"	YES
Self Clear Span Time	Should not be modified, and keep the original value	YES
Hvg Prep On	Reserved	YES
Hvg XRay Enable	Reserved	YES
Hvg XRay On	Reserved	YES
Tube Ready Time	Reserved	YES
Image Pkg Gap Time	Reserved	YES
Out Mode Cap Trigger	Reserved	YES

4.10.3.2. SDK Settings

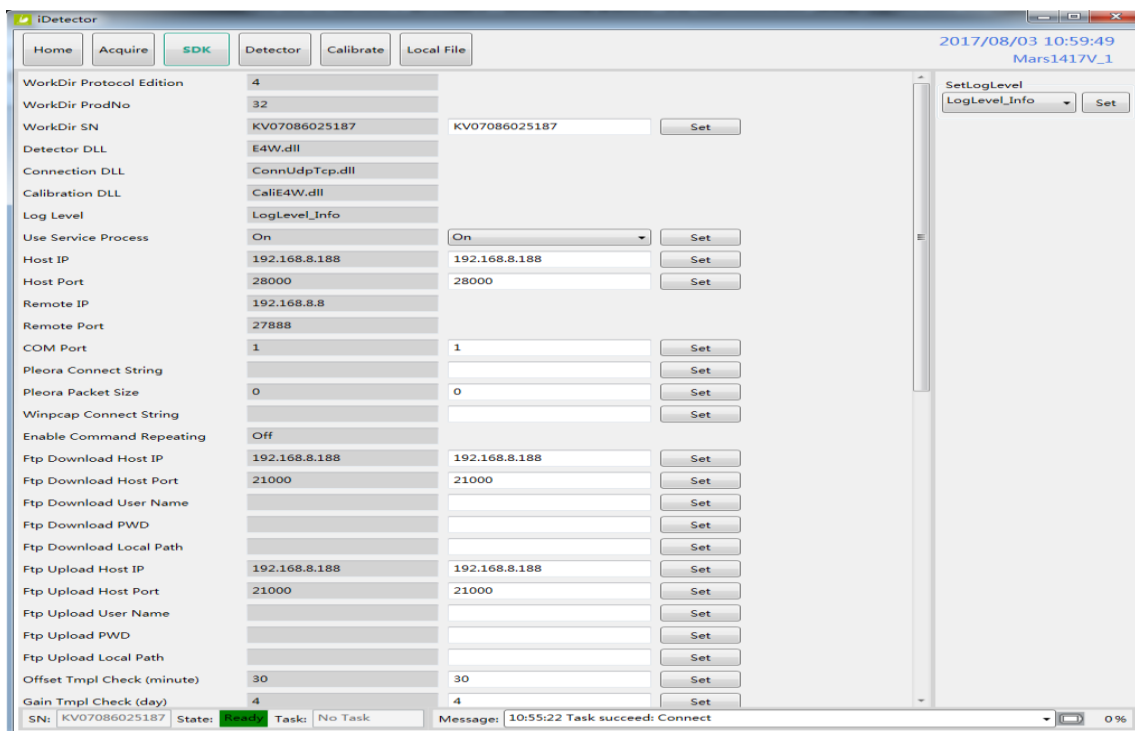

Only the following parameters need to be concerned

	Description	Modify
Host IP	IP Address of local workstation	YES
Host Port	Port of local workstation	YES
Ftp Download Host IP	FTP download server IP, keep the same as Host IP	YES
Ftp Download Host Port	FTP download server Port, keep the same as Host Port	YES
Ftp Upload Host IP	FTP upload server IP, keep the same as Host IP	YES
Ftp Upload Host Port	FTP upload server Port, keep the same as Host Port	YES

4.10.3.3. Network Settings

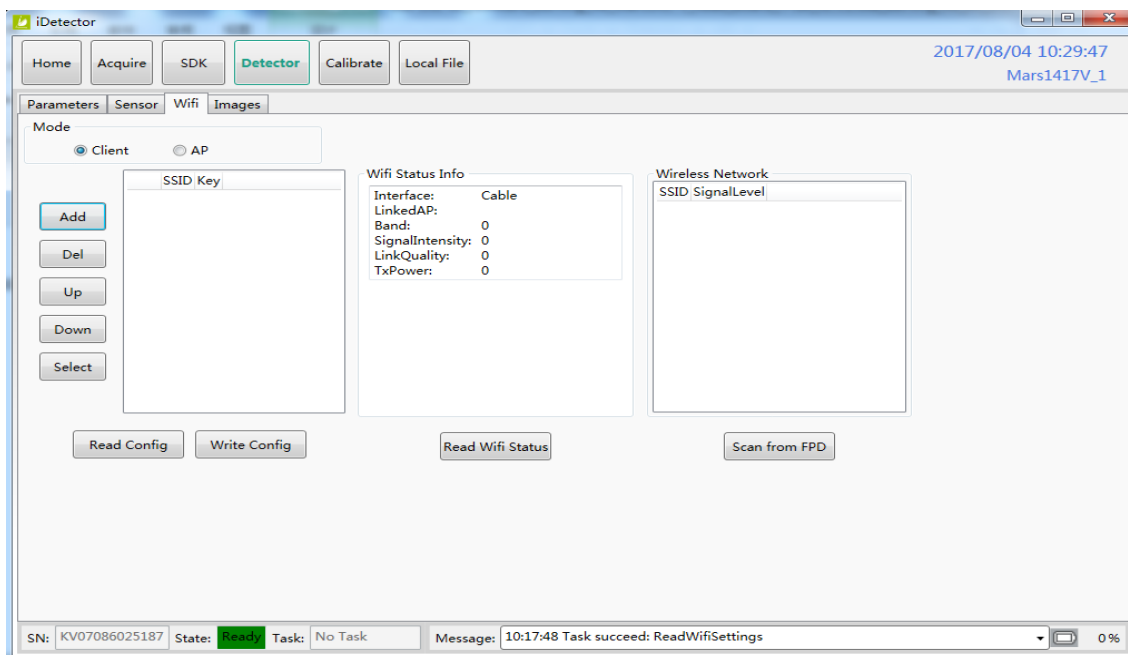

Description		Modify
Add	Add the information of SSID and Key of the AP	/
Del	Delete the information of SSID and Key of the AP	/
Up	Move up the AP information	/
Down	Move down the AP information	/
Select	Select the AP	/
Read Config	Read the parameters of the AP information when the detector is set as AP	/
Write Config	Write the parameters of the AP information when the detector is set as AP	/
Read Wifi Status	Read the wifi status of the current detector	/
Scan from FPD	Scan the AP	/

4.11. List of the HAZARDOUS SITUATIONS resulting from a failure of the IT-NETWORK

- 1) The operating system is not compatibility;
- 2) Change or update the software failed;
- 3) The compatibility of the interface;
- 4) The data transfer protocol error;
- 5) The inconsistent of interface or format leads to data distortion;
- 6) The data output failed;

5. REGULATORY INFORMATION..... 81

5.1. Medical equipment safety standards81

5.2. The compliance for each EMISSIONS and IMMUNITY standard or test specified by IEC60601-1-2 standard82

5.3. Radio Frequency Compliance Information.....85

5.3.1. FCC Compliance85

5.4. Battery Safety Standards.....86

5. Regulatory Information

5.1. Medical equipment safety standards

Medical equipment classification

Type of protection against electrical shock	External electrical power source equipment Class I Equipment (medical approved adaptor) Internal electrical power source equipment (battery)
Degree of protection against electrical shock	Type-B applied part
Degree of protection against ingress of water	IPX1
Mode of operation	Continuous operation
Flammable anesthetics	Not suitable for use in the presence of a flammable anesthetic mixture with air or with oxygen or nitrous oxide Not suitable for use in the oxygen rich environment

Product safety standards

MDD (93/42/EEC)	Medical Device Directive
ISO 13485:2016	Medical devices -- Quality management systems -- Requirements for regulatory purposes
IEC 60601-1:2005/AMD1:2012	Medical electrical equipment -- Part 1: General requirements for basic safety and essential performance
IEC 60601-1-2:2014/EN60601-1-2:2015	Medical electrical equipment – Part 1-2: General requirements for basic safety and essential performance – Collateral standard: Electromagnetic disturbances – Requirements and tests
IEC 60601-2-54:2015/EN 60601-2-54:2015	Medical electrical equipment -- Part 2-54: Particular requirements for the basic safety and essential performance of X ray equipment for radiography and radioscopy
IEC 62133:2012	Secondary cells and batteries containing alkaline or other non-acid electrolytes – Safety requirements for portable sealed secondary cells, and for batteries made from them, for use in portable applications
IEC 62220-1:2003 EN 62220-1:2004	Medical electrical equipment - Characteristics of digital X-ray imaging devices - Part 1: Determination of the detective quantum efficiency
IEC 62304:2006/AMD1:2015	Medical device software - Software life-cycle processes
IEC 62366-1:2015/IEC 62366:2007/EN 62366:2008	Medical devices –part 1: Application of usability engineering to medical devices
IEC 60601-1-6:2010+A1:2013	Medical electrical equipment - Part 1-6: General requirements for basic safety and essential performance - Collateral standard: Usability
EN ISO14971: 2012	Medical device – Application of risk management to medical devices
ANSI/AAMI ES60601-1:2005/(R)2012+A1:2012+C1:2009/(R)2012+A2:2010/(R)2012	Medical electrical equipment - Part 1: General requirements for basic safety and essential performance (IEC 60601-1:2005, MOD)

CAN/CSA-C22.2 No.60601-1:14	Medical electrical equipment – Part 1: General requirements for basic safety and essential performance
ISO 15223-1:2016/ EN ISO 15223-1:2016	Medical devices—Symbols to be used with medical device labels, labeling and information to be supplied—Part 1: General requirements

5.2. The compliance for each EMISSIONS and IMMUNITY standard or test specified by IEC60601-1-2 standard

EMI Compliance Table

Emission

Phenomenon	Compliance	Electromagnetic environment
RF emissions	CISPR 11 Group 1, Class B	Professional healthcare facility environment
Harmonic distortion	IEC 61000-3-2 Class A	Professional healthcare facility environment
Voltage fluctuations and flicker	IEC 61000-3-3 Compliance	Professional healthcare facility environment

EMS Compliance Table

Enclosure Port

Phenomenon	Basic standard	EMC	Immunity test levels
			Professional healthcare facility environment
Electrostatic Discharge	IEC 61000-4-2		±8 kV contact ±2kV, ±4kV, ±8kV, ±15kV air
Radiated RF EM field	IEC 61000-4-3		3V/m 80MHz-2.7GHz 80% AM at 1kHz
Proximity fields from RF wireless communications equipment	IEC 61000-4-3		Refer to table “Proximity fields from RF wireless communications equipment”
Rated power frequency magnetic fields	IEC 61000-4-8		30A/m 50Hz or 60Hz

Proximity fields from RF wireless communications equipment

Test frequency (MHz)	Band (MHz)	Immunity test levels
		Professional healthcare facility environment
385	380-390	Pulse modulation 18Hz, 27V/m
450	430-470	FM, ±5kHz deviation, 1kHz sine, 28V/m

710	704-787	Pulse modulation 217Hz, 9V/m
745		
780		
810	800-960	Pulse modulation 18Hz, 28V/m
870		
930		
1720	1700-1990	Pulse modulation 217Hz, 28V/m
1845		
1970		
2450	2400-2570	Pulse modulation 217Hz, 28V/m
5240	5100-5800	Pulse modulation 217Hz, 9V/m
5500		
5785		

Input AC power Port

Phenomenon	Basic EMC standard	Immunity test levels
		Professional healthcare facility environment
Electrical transients/burst fast	IEC 61000-4-4	±2 kV 100kHz repetition frequency
Surges Line-to-line	IEC 61000-4-5	±0.5 kV, ±1 kV
Surges Line-to-ground	IEC 61000-4-5	±0.5 kV, ±1 kV, ±2 kV
Conducted disturbances induced by RF fields	IEC 61000-4-6	3V, 0.15MHz-80MHz 6V in ISM bands between 0.15MHz and 80MHz 80% AM at 1kHz
Voltage dips	IEC 61000-4-11	0% UT; 0.5 cycle At 0°, 45°, 90°, 135°, 180°, 225°, 270° and 315°
		0% UT; 1 cycle and 70% UT; 25/30 cycles Single phase: at 0°
Voltage interruptions	IEC 61000-4-11	0% UT; 250/300 cycles

Input DC power Port

Phenomenon	Basic EMC standard	Immunity test levels
		Professional healthcare facility environment
Electrical transients/burst fast	IEC 61000-4-4	±2 kV 100kHz repetition frequency
Conducted disturbances induced by RF fields	IEC 61000-4-6	3V, 0.15MHz-80MHz 6V in ISM bands between 0.15MHz and 80MHz 80% AM at 1kHz

Signal input/output parts Port

Phenomenon	Basic EMC standard	Immunity test levels
		Professional healthcare facility environment
Electrostatic Discharge	IEC 61000-4-2	±8 kV contact ±2kV, ±4kV, ±8kV, ±15kV air
Electrical transients/burst fast	IEC 61000-4-4	±1 kV 100kHz repetition frequency
Conducted disturbances induced by RF fields	IEC 61000-4-6	3V, 0.15MHz-80MHz 6V in ISM bands between 0.15MHz and 80MHz 80% AM at 1kHz

The following shows information on reference cables provided against EMC

Cable	Recommended cable length	Shielded or Unshielded	Number	Cable classification
AC Power Cable	3m	Unshielded	1 pcs	AC Power
DC Power Cable	3.5m	Unshielded	1 pcs	DC Power
LAN Cable (configuration mode)	3m	Shielded	1 pcs	Signal

- Important information regarding Electromagnetic Compatibility (EMC)

Mars1417V requires special precautions regarding EMC and needs to be installed only by our company or authorized personnel and put into service according to EMC information provided in the user manual. Mars1417V in use may be susceptible to electromagnetic interference from portable and mobile RF communications such as mobile (cellular) telephones. Electromagnetic interference may result in

incorrect operation of the system and create a potentially unsafe situation. The minimum distance between the panel and other equipment should be larger than 12 inch.

Mars1417V conforms to this EN60601-1-2:2015 standard for both immunity and emissions.

Nevertheless, special precautions need to be observed:

The use of accessories, transmitters and cables other than those specified by this User Manual, with the exception of accessories and cables sold by our company of Mars1417V as replacement parts for inner components, may result in increased emission or decreased immunity.

5.3. Radio Frequency Compliance Information

Country	Item
U.S.A	FCC Part 15.107 Sub part (b) / 15.109(g) Sub part B FCC Part 15 Sub part E 15.407 FCC Part 15 Sub part C 15.247
European Union	ETSI EN 301 489-1 V1.8.1 (EMC) ETSI EN 301 489-17 V2.1.1 (EMC) EN 300 328 V.1.7.1; EN 301 893 V1.6.1 (RF) EN 62311:2008 (RF Exposure) ETSI EN 300 328 V1.7.1; EN 301 893, V1.5.1 (Radio Spectrum)

5.3.1. FCC Compliance

- The panel has been tested to comply with limits for a Class B digital device, pursuant to part 15 of FCC Rules. These limits are designed to provide reasonable protection against harmful interference in a residential installation.
- Operation is subject to the following two conditions.
The panel may not cause harmful interference.
The panel must accept any interference received, including interference that may cause undesired operation.
- The panel generates, uses, and radiates radio frequency energy and, if not installed and used in accordance with the instruction, may cause harmful interference to radio communications. However, there is no guarantee that interference will not occur in a particular installation. If the panel does cause harmful interference to radio or television reception, which can be determined by turning the panel off and on, the user is encouraged to correct the interference by one or more of the following measure.
Reorient or relocate the antenna.
Increase the separation between the panel and receiver.

Connect the panel into an outlet different from the receiver is connected.

Consult the distributor or an experienced radio/TV technician for help.

5.4. Battery Safety Standards

Standards	Description
CAN/CSA E62133:13 1st Ed. Rev.	Secondary cells and batteries containing alkaline or other non-acid electrolytes - Safety requirements for portable sealed secondary cells, and for batteries made from them, for use in portable applications First Edition
UL 62133, 1st Ed. Rev.	Secondary cells and batteries containing alkaline or other non-acid electrolytes - Safety requirements for portable sealed secondary cells, and for batteries made from them, for use in portable applications First Edition
UL 2054	Household and commercial Batteries
IEC 62133:2012	Secondary cells and batteries containing alkaline or other non-acid electrolytes
UN38.3	United Nations Recommendations on the Transport of dangerous goods Manual of tests and Criteria ST/SG/AC.10/11/Rev.5/Amend.1&Amend.2

6. TROUBLE SHOOTING..... 88

6. Trouble Shooting

Please refer to service manual. If the problem persists, turn off the panel and contact service department.

We would provide the best service.

7. SERVICE INFORMATION	90
7.1. Product Lifetime.....	90
7.2. Regular Inspection and Maintenance.....	90
7.3. Repair.....	90
7.4. Replacement Parts Support.....	90

7. Service Information

7.1. Product Lifetime

The estimated product lifetime is up to 7 years under appropriate regular inspection and maintenance (battery 5 years).

7.2. Regular Inspection and Maintenance

In order to ensure the safety of patients and operator, to maintain the performance and reliability of the panel, be sure to perform regular inspection at least once a year. If necessary, clean up the panel, make adjustments or replace consumables such as fuses etc. There may be cases where overhaul is recommended depending on conditions. Contact service office or local dealer for regular inspection or maintenance.

7.3. Repair

If problem cannot be solved, contact your sales representative or local dealer for repairs. Please refer to the label and provide the following information:

Product Name:

Series Number:

Description of Problem: as clearly as possible.

7.4. Replacement Parts Support

Main parts (parts required to maintain the function of the product) of this product will be stocked for 5 years after discontinuance of production for repairing.