

Flat Panel Detector

Venu1717X

User Manual



Version : A1

Doc ID : 072-201-11

Release Date:: 2021.09.07



Before operating, please read this user manual and pay attention to all safety precautions.

Please ensure that this user's manual is properly maintained so that it can be accessed at any time (reserve).

Please use it correctly on the basis of full understanding of the content.

Congratulations on your purchase of the Flat Panel Detector (hereinafter referred to as Venu1717X) which is manufactured by iRay Technology Ltd. (Hereinafter referred to as iRay).

Please take time to read through this user guide in order to utilize the product effectively. We hope you enjoy the experience with iRay Venu1717X.

If you have any questions or suggestions, please feel free to contact us.

Service Office

Tel: +86 021-50720560

Fax: +86 021-50720561

E-mail: service@iraygroup.com

**Location: Rm. 202, Building 7, No. 590, Ruiqing Rd., Zhangjiang East,
Pudong PC: 201201**

Notes on usage and management of the equipment

1. Read all of the instructions in the user guide before your operation. Give particular attention to all safety precautions.
2. Only a physician or a legally certified operator should use this product.
3. The equipment should be maintained in a safe and operable condition by maintenance personnel.
4. Use only computers and image display monitors complying with IEC 60601-1 or IEC 60950-1. For details, consult our sales representative or local iRay dealer.
5. Use only the dedicated cables. Do not use any cables other than those supplied with this product.
6. Request your sales representative or local iRay dealer to install this product.

Caring for your environment



This symbol indicates that this product is not to be disposed of with your residential or commercial waste.

Recycling iRay Equipment

Please do not dispose of this product with your residential or commercial waste. Improper handling of this type of waste could have a negative impact on health and on the environment. Some countries or regions, such as the European Union, have set up systems to collect and recycle electrical or electronic waste items. Contact your local authorities for information about practices established in your region. If collection systems are not available, call iRay Customer Service for assistance.

Disclaimer

1. iRay shall not be liable to the purchaser of this product or third parties for any damage, loss, or injury incurred by purchaser or third parties as a result of fire, earthquake, any accident, misuse or abuse of this product.
2. iRay shall not be liable to any damage, loss, or injury arising from unauthorized modifications, repairs, or alterations to this product or failure to strictly comply with iRay's operating and maintenance instructions.
3. iRay shall not be liable for any damage or loss arising from the use of any options or consumable products other than those dedicated as Original iRay Products by iRay Technology.
4. It is the responsibilities of the user/attending physicians for maintaining the privacy of image data and providing medical care services. iRay shall not be responsible for the legality of image processing, reading and storage nor it shall be responsible for loss of image data for any reason.
5. Information regarding specification, compositions, and appearance of this product is subject to change without prior notice.

Copyright

All rights reserved







No part of this publication may be reproduced in any form or by any means without the written permission of iRay. The information contained herein is designed only for use with iRay Venu1717X.

Trademarks

The iRay name and iRay logo are registered trademarks of iRay Technology Co. Ltd.











Symbols and Conventions









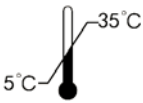
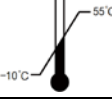

The following symbols and conventions are used throughout the user guide.

	<p>This symbol is used to identify conditions under which improper use of the product may cause death or serious personal injury.</p>
	<p>This notice is used to identify conditions under which improper use of the product may cause minor personal injury.</p>
	<p>This notice is used to identify conditions under which improper use of the product may cause property damage.</p>
	<p>This is used to indicate a prohibited operation.</p>
	<p>This is used to indicate an action that must be performed</p>
	<p>This is used to indicate important operations and restrictions.</p>
	<p>This is used to indicate operations for reference and complementary information.</p>

Labels and markings on the equipment

The contents of the labels and markings on iRay Venu1717X product are indicated below:

Symbol	Description
	<p>Caution: please refer to the instructions in the user manual.</p>
	<p>This symbol is used to indicate that the equipment has passed CE testing and it is followed by the CE Notified Body number.</p>
	<p>This symbol is used to identify the serial number.</p>
	<p>This symbol is used to indicate the name and address of the manufacturer.</p>
	<p>Manufacturing date of this product.</p>
	<p>Expiring date of this product.</p>
	<p>This symbol is used to indicate the name and address of iRay authorized representative in the European region.</p>
	<p>This symbol is used to indicate consultation of the user guide for general information.</p>
	<p>This product is not to be disposed of with your residential or commercial waste.</p>
	<p>Safety Signs: please refer to the user guide for safety instructions.</p>
	<p>Safety Signs: Dangerous Voltage.</p>

	B Type.
	This symbol indicates load limit.
	Handled with care.
	This symbol is used to indicate the operational temperature limits.
	This symbol is used to indicate the storage temperature limits.
	Package symbol, fragile.
	Package symbol, keep away from sunlight.
	Package symbol, keep dry.
	Package symbol, this symbol is used to indicate the humidity limits.
	Package symbol, keep the equipment up right.
	Package symbol, do not roll the transportation package.
	Package symbol, this symbol is used to indicate stacking limit number.
ON	Switch to this position means power on for part of the equipment
OFF	Switch to this position means power off for part of the equipment

Contents



CONTENTS	6
1. SAFETY INFORMATION	7
1.1 Safety Precautions	8
1.2 Notes for Using	13
2. GENERAL DESCRIPTION	14
2.1 Product Description	15
2.2 Principle	15
2.3 Scope	15
2.4 Model	16
2.5 Characteristics	16
2.6 Intended Use	16
2.7 Environment	17
2.8 Product Components	17
2.9 Specification	22
3. INSTALL	24
3.1 Control Box Installation.....	25
3.2 Cable Connection	25
4. SOFTWARE SETUP	28
4.1 System requirement	29
4.2 Environment setup.....	29
4.3 Wired Connection	29
4.4 Software UI	31
4.5 List of the HAZARDOUS SITUATIONS resulting from a failure of the IT-NETWORK	48
5. OPERATION INSTRUCTIONS FOR IMAGE ACQUISITION	49
5.1 Steps for acquiring image.....	50
5.2 Software Mode.....	50
5.3 Prep Mode	52
5.4 FreeSync Mode	54
5.5 Inner Mode.....	55
5.6 After use	57
6. REGULATORY INFORMATION	58
6.1 Medical equipment safety standards	59
6.2 Guidance and manufacture's declaration for EMC.....	60
6.3 Product Label.....	63
7. SERVICE INFORMATION	65
7.1 Product lifetime	66
7.2 Regular inspection and Maintenance	66
7.3 Repair	66
8. APPENDIX	67
Appendix A Information of Manufactures	68
Appendix B Information of Europe Representative	69
Appendix C the compatible interface circuit of the Enable_Out_P.....	70



1. Safety Information



1.1 <i>Safety Precautions</i>	8
1.2 <i>Notes for Using</i>	13



1.1 Safety Precautions



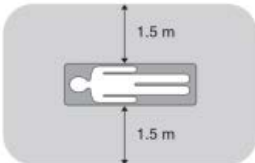
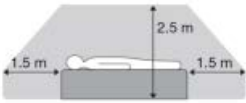

Follow these safeguards and properly use the equipment to prevent injury and damage to any equipment/data

WARNING	
<p>Installation and environment of use</p>  <p>Prohibited</p>	<p>Do not use or store the equipment near flammable chemicals such as alcohol, thinner, benzene, etc.</p> <p>If chemicals are spilled or evaporate, it may result in fire or electric shock through contact with electric parts inside the equipment. Also, some disinfectants are flammable. Be sure to take care when using them.</p> <p>Do not connect the equipment with anything other than specified.</p> <p>Doing so may result in fire or electric shock.</p> <p>All the patients with active implantable medical devices should be kept away from the equipment.</p>
<p>Power supply</p>  <p>Prohibited</p>	<p>Do not operate the equipment using any type of power supply other than the one indicated on the rating label.</p> <p>Otherwise, it may result in fire or electric shock.</p> <p>Do not handle the equipment with wet hands.</p> <p>You may experience electric shock that could result in death or serious injury.</p> <p>Do not place heavy object such as medical equipment on cables and cords. Do not pull, bend, bundle, or step on them to prevent their sheath from being damaged, and do not alter them neither.</p> <p>Doing so may damage the cords, which could result in fire or electric shock.</p> <p>Do not supply power to more than one piece of equipment using the same AC outlet.</p> <p>Doing so may result in fire or electric shock.</p> <p>Do not turn ON the system power when condensation has formed on the equipment.</p> <p>Doing so may result in fire or electric shock.</p>
<p>Power supply</p>  <p>Prohibited</p>	<p>Do not connect a multiple portable socket-outlet or extension cord to the system.</p> <p>Doing so may result in fire or electric shock.</p> <p>To avoid the risk of electric shock, this equipment must only be connected to power supply with protective earth.</p> <p>Not doing so may result in fire or electric shock.</p>

	<p>Securely plug the power cord into the AC outlet. If contact failure occurs, or if metal objects come into contact with the exposed metal prongs of the plug, fire or electric shock may result.</p> <p>Be sure to turn OFF the power to each piece of equipment before connecting or disconnecting the cords. Otherwise, you may get an electric shock that could result in death or serious injury.</p> <p>Be sure to hold the plug or connector to disconnect the cord. If you pull the cord, the core wire may be damaged, resulting in fire or electric shock.</p>
<p>WARNING</p>	
<p>Handling</p>  <p>Prohibited</p>	<p>Never disassemble or modify the equipment. No modification of this equipment is allowed. Parts of the Venu1717X that are not serviced or maintained while in use with the patient. Doing so may result in fire or electric shock. Also, since the equipment incorporates parts that may cause electric shock as well as other hazardous parts, touching them may cause death or serious injury.</p> <p>Do not place anything on top of the equipment. The object may fall and cause an injury. Also, if metal objects such as needles or clips fall into the equipment, or if liquid is spilled, it may result in fire or electric shock.</p> <p>Do not hit or drop the equipment. The equipment may be damaged if it receives a strong jolt, which may result in fire or electric shock if the equipment is used without being repaired.</p> <p>Do not put the equipment and pointed objects together. The equipment may be damaged. If so, the equipment should be used in bucky.</p>
	<p>Have the patient take a fixed posture and do not let the patient touch parts unnecessarily. If the patient touches connectors or switches, it may result in electric shock or malfunction of the equipment.</p>

<p>When a problem occurs</p>	<p>Should any of the following occurs, immediately unplug the power cord of Control Box, and contact your sales representative or local iRay dealer:</p> <p>When there is smoke, an odd smell or abnormal sound.</p> <p>When liquid has been spilled into the equipment or a metal object has entered through an opening.</p> <p>When the equipment has been dropped and damaged.</p>
<p>Maintenance and inspection</p>  <p>Prohibited</p>	<p>Please turn OFF the power of the equipment and unplug the power cord of adaptor before cleaning.</p> <p>NEVER use alcohol, ether and other flammable cleaning agent for safety. NEVER use methanol, benzene, acid and base because they will erode the equipment.</p> <p>DON'T dip the equipment into the liquid.</p> <p>Please make sure that the equipment's surface & plugs are dry before turning ON.</p> <p>Otherwise, it may result in fire or electric shock.</p>
	<p>Clean the plug of the power cord periodically by unplugging it from the AC outlet and removing dust or dirt from the plug, its periphery and AC outlet with a dry cloth.</p> <p>If the cord is kept plugged in for a long time in a dusty, humid or sooty place, dust around the plug will attract moisture; this could cause insulation failure that may result in a fire.</p> <p>For safety reasons, be sure to turn OFF the power to each piece of equipment when performing inspections indicated in this manual.</p> <p>Otherwise, electric shocks may occur.</p>

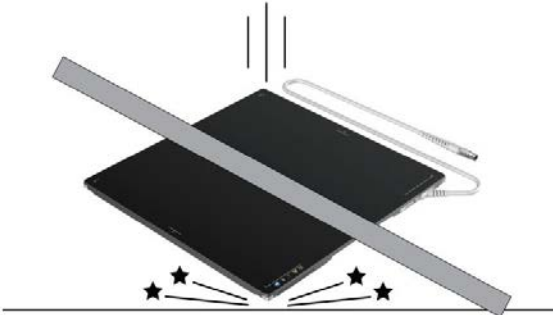
CAUTION	
<p>Installation and environment of use</p> 	<p>Do not install the equipment in any of the locations listed below. Doing so may result in failure, malfunction, equipment falling, fire or injury.</p> <ul style="list-style-type: none"> Close to facilities where water is used Where it will be exposed to direct sunlight Close to the air outlet of an air-conditioner or ventilation equipment Close to heat source such as a heater Where the power supply is unstable In a dusty environment In a saline or sulfurous environment Where temperature or humidity is high Where there is freezing or condensation In areas prone to vibration On an incline or in an unstable area <p>Take care that cables do not become tangled during use. Also, be careful not to get your feet caught by cable.</p> <p>Otherwise, it may cause a malfunction of the equipment or injury of the user due to tripping over the cable.</p> <div style="display: flex; justify-content: space-around; align-items: center;">   </div>
<p>Power supply</p> 	<p>Always connect the three-core power cord plug to a grounded AC power outlet.</p> <p>To make it easy to disconnect the plug at any time, avoid putting any obstacles near the outlet. Otherwise, it may not be possible to disconnect the plug in an emergency.</p> <p>Be sure to ground the equipment to an indoor grounded connector. Also, be sure to connect all the grounds for the system to a common ground.</p> <p>Do not use any power source other than the one provided with this equipment.</p> <p>Otherwise, fire or electric shock may be caused due to leakage.</p>

<p>Handling</p> 	<p>Do not spill liquid or chemicals onto the equipment. In case the patient is injured, it is not allowed to contact with blood or other body fluids.</p> <p>Doing so may result in fire or electric shock.</p> <p>In such a situation, protect the equipment with a disposable cover as necessary.</p> <p>Turn OFF the power and pull out the plug to each piece of equipment for safety when not used.</p>
<p>CAUTION</p>	
<p>Handling</p> 	<p>Handle the equipment carefully.</p> <p>Do not submerge the equipment in water.</p> <p>The internal image sensor may be damaged if</p>  <p>something hits against it or it is dropped.</p> <p>Do not place excessive weight on the equipment.</p> <p>Be sure to use the equipment on a protected foam. Otherwise, the internal image sensor may be damaged. Be sure to securely hold the detector while using it in upright positions. Otherwise, the detector may fall over, resulting in injury to the user or patient, or may flip over, resulting in damage to the inner device.</p> <p>Keep the same load (same pressure) on the detector when acquiring the image. Or the image will be incorrect.</p>
<p>CAUTION</p>	
 <p>CAUTION</p>	<p>Do not close to fire, do not use in high temperature</p> <p>Do not invert positive and negative pole</p> <p>Do not contact with metal in case of short circuit</p>

1.2 Notes for Using

When using the product, take the following precautions. Otherwise, problems may occur and the product may not function correctly.

Before exposure

- Be sure to check the connection of all the parts are set properly & check the detector is kept in insulated cover that operator or patient can't touch the detector directly before powered up.
- Be sure to check the product daily and confirm it work properly.
- Sudden heating of the room in cold areas will cause condensation on the product. In this case, wait until the condensation evaporates before performing an exposure. If it is used when condensation is formed, problems may occur in the quality of captured images. When an air-conditioner is used, be sure to raise/lower the temperature gradually to prevent condensation.
- The product should be warmed up for 15 minutes before exposure or updating the gain map and defect map.
- Make sure exposure dose rate is over 900nGy/s.
- Make sure wave form of the energy going to the X ray tube is square not pulse.
- Be cautious with circumstance that someone has radio isotope recently injected into them, it may cause panel transmit image without x ray.
- Once powered off, please wait at least 60s before power on again

During exposure

- Do not move Power Cable or Ethernet Cable during exposure, or it may cause image noise or artifacts, even incorrect images.
- Do not use the product near the equipment generating a strong magnetic field. Otherwise, it may cause image noise, artifacts or even incorrect images.

After Usage

- After every examination, wipe the patient contact surfaces with disinfectants such as ethanol, to prevent the risk of infection. For details on how to sterilize, consult a specialist.
- Do not spray the product directly with disinfectants or detergents.
- Wipe it with a cloth slightly damped with a neutral detergent. Do not use solvents such as alcohol, benzene and acid. Doing so may damage the surface of the product.
- It's recommended to use a waterproof non-woven cover as the isolated layer between product and the bleeding patient.

2. General Description

2.1	<i>Product Description</i>	15
2.2	<i>Principle</i>	15
2.3	<i>Scope</i>	15
2.4	<i>Model</i>	16
2.5	<i>Characteristics</i>	16
2.6	<i>Intended Use</i>	16
2.7	<i>Environment</i>	17
2.8	<i>Product Components</i>	17
2.9	<i>Specification</i>	22

2.1 Product Description

Venu1717X is a cassette-size tethered X-ray flat panel detector based on amorphous silicon thin-film transistor technology. It is designed to provide the high quality radiographic image which contains an active matrix of 3072×3072 with 139um pixel pitch. The scintillator of Venu1717X is CsI(Caesium Iodide). The technology of CsI direct growth reduces the exposure dose and improves the image quality. Since Venu1717X supports multiple trigger modes, it can satisfy both of the general DR system and retrofit DR system.

2.2 Principle

Detectors contain a layer of scintillator material, which converts the x-rays into light. Directly behind the scintillator layer is an amorphous silicon pixel array contains a photodiode which generates an electrical signal in proportion to the light produced by the portion of scintillator layer in front of the pixel. The signals from the photodiodes are amplified and encoded by additional electronics positioned behind the sensor array in order to produce an accurate and sensitive digital representation of the x-ray image.

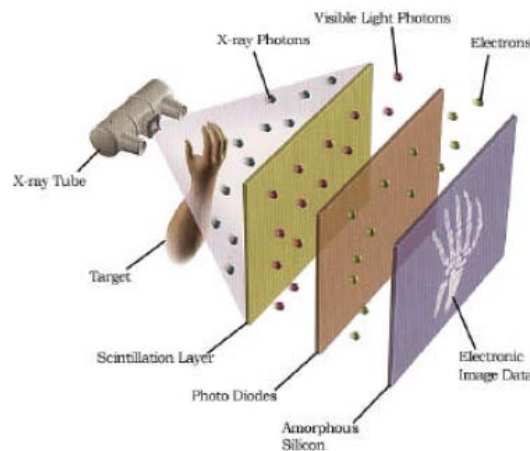

2.3 Scope

This manual contains information about iRay Venu1717X product. All operators must read and understand this manual before using equipment. All information in this manual, including the illustrations, is based on equipment prototype. If configuration of your equipment does not have any of these items, information about these items in the manual does not apply to your equipment.

2.4 Model

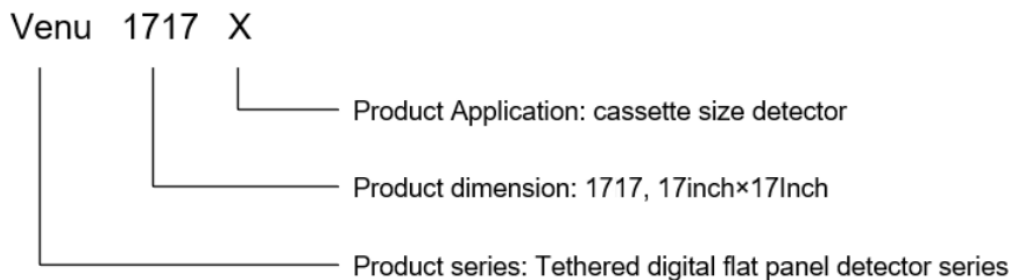

2.5 Characteristics

- Tethered static flat panel detector
- 17 inch ×17 inch
- Replaceable Cable
- Removable handle
- AED Function
- GigE
- 16-bit AD

2.6 Intended Use

This equipment provides digital X-ray imaging for diagnosis of disease, injury, or any applicable health problem. The image is obtained as the result of X-ray passing through the human body and detected by the equipment.

IRay will provide equipment and software support for integration of system.

This panel is not intended for mammography or dental applications, and not recommend for pregnant women and new born.

According to the Venu1717X intended use and the result of risk management, identifying and describing the essential performance as the following:

To get image of dark field, the Venu1717X shall be not influenced to the imaging acquisition



To keep the data transmission function, the Venu1717X shall be not influenced to the data and signal transmission





2.7 Environment

	Temperature	Temperature change	Humidity	Atmospheric Pressure	Pressure Change
Operating	5~35°C	≤0.5°C /min	30~80% RH	700~1060mbar	≤10 mbar/hour
Storage	10~55°C	≤1°C /min	10~90% RH		≤20 mbar/hour

- The Venu1717X serial detectors shall operate at an altitude specified no more than 3000m.
- Do not expose the equipment to high temperature and humidity, which will result in equipment failure.

2.8 Product Components

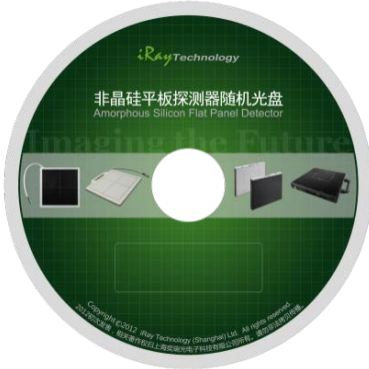
Item	Picture	Description
Venu1717X Detector		1pcs
Control Box		1pcs
Medical Adapter		1pcs

AC Power Cable		1pcs
Gigabit Ethernet Cable		1pcs
HVG Cable		1pcs
CD-ROM		1 pcs Gain correction map Defect correction map SDK Manual
Syncbox		Optional

2.8.1 Detector

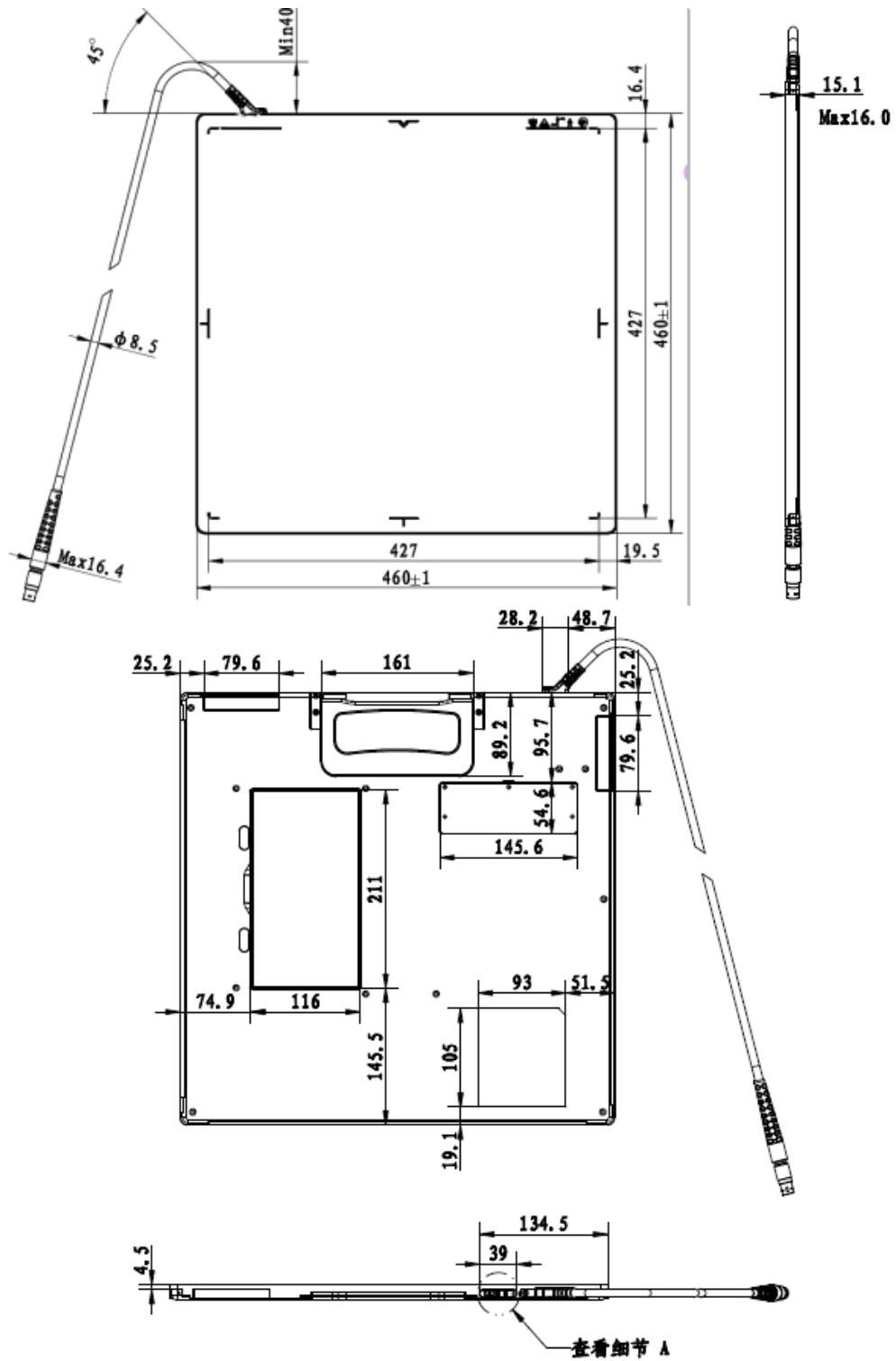

The extended cable length:1m

2.8.2 Indicator

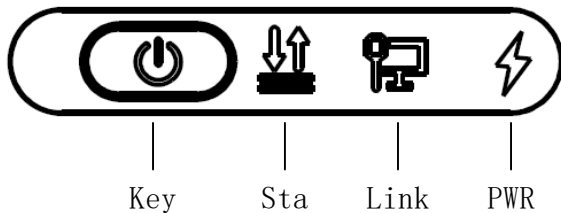

	Lighting Status	Operating Status
Power indicator	OFF	1. Power OFF
	Green ON	1. Power ON with DC Input.
Link indicator	OFF	1. Power OFF 2. Wired Connection broken
	Blue ON	Connected with Control Box
	Green ON	Connected with SDK
Status indicator	OFF	1. Power OFF 2. Panel is idle
	Green blinking	Data Transmission
	Orange blinking	Fatal Error

2.8.3 Control Box

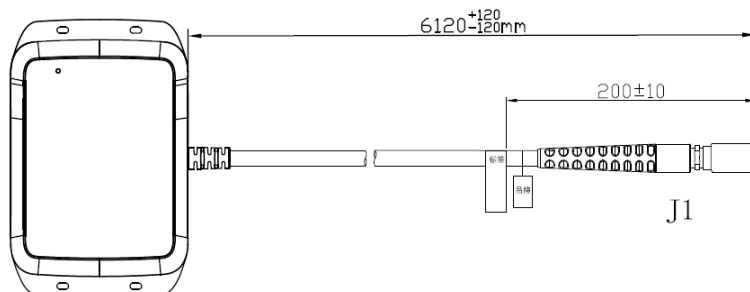

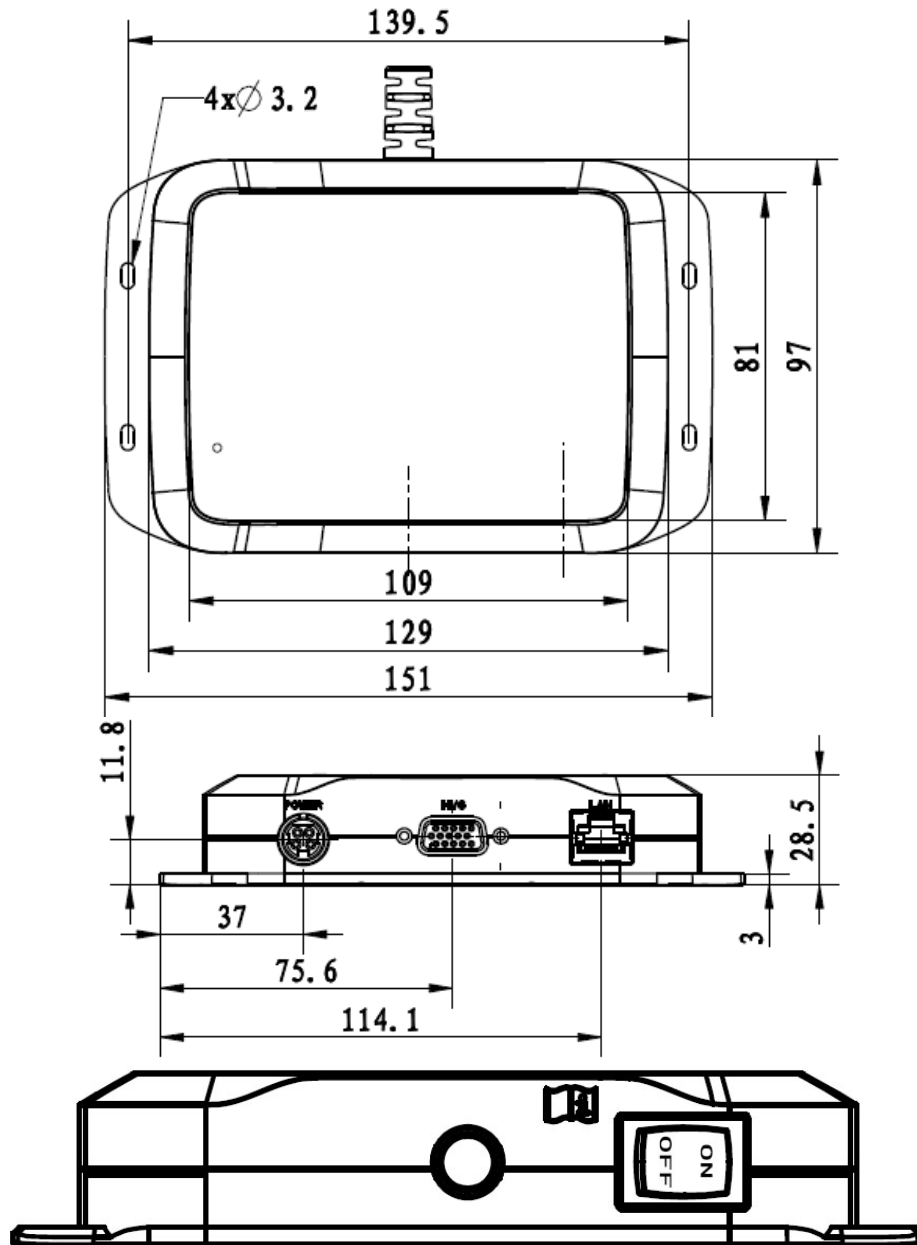

Item	Description
J1	Composite Interface for Detector
POWER	DC Input Interface for Adapter
HVG	HVG Interface for Generator
LAN	Network Interface for Workstation
OFF	Switch to this position means power off for part of the equipment
ON	Switch to this position means power on for part of the equipment

2.8.4 Adapter

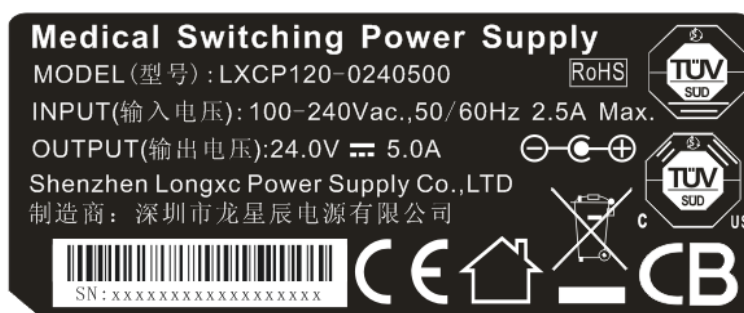
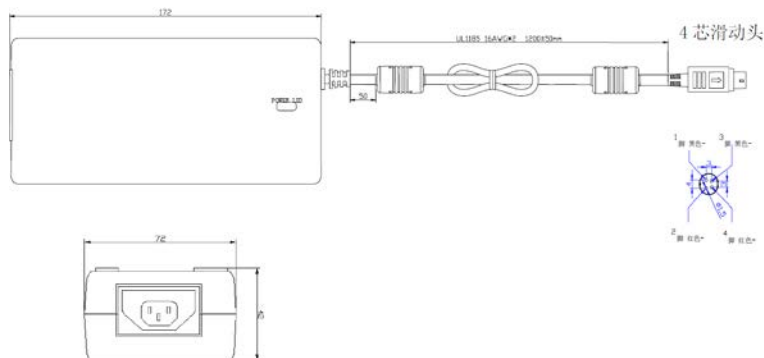

2.9 Specification

2.9.1 Basic

Item	Specification
Model	Venu1717X
Image Sensor	a-Si (Amorphous Silicon) TFT
Scintillator	CsI:Tl
Pixel Size	139um
Fill Factor	70%
Effective Array	3072x3072
Effective Area (H x V)	427mm×427mm
Spatial Resolution	Min. 3.4 lp/mm
Image Transfer	Gigabit Ethernet
Full Image Time	5s
Cycle Time	8s

Power Consumption	20W
Dimension (L × W × H)	460mmx460mmx15mm
Weight	4kg(without cable and control box)
X-ray Energy	40-150kV
Panel protection	IPX1
Trigger Mode	Software Prep Freesync Inner
SID	90-180cm

3. Install



3.1	<i>Control Box Installation</i>	25
3.2	<i>Cable Connection</i>	25

3.1 Control Box Installation

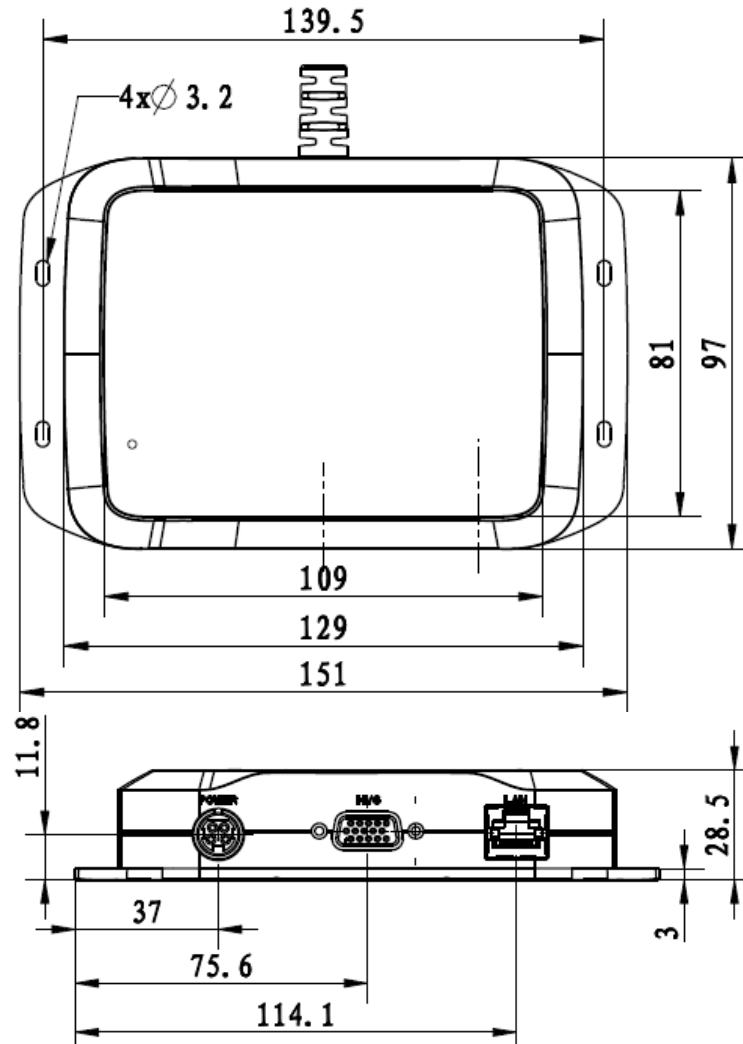
There are four mounting holes at the bottom of Control Box. Before installation, make sure the power is OFF.



3.2 Cable Connection

<p>Connect Power, HVG (if needed), and Gigabit cables to the Control Box.</p>	
<p>Connect the HVG cable to High Voltage Generator</p>	

3.2.1 Pin and Cable Definition

The high-voltage interface on the control box adopts 3 rows of DB15 female heads, as shown in the following figure:

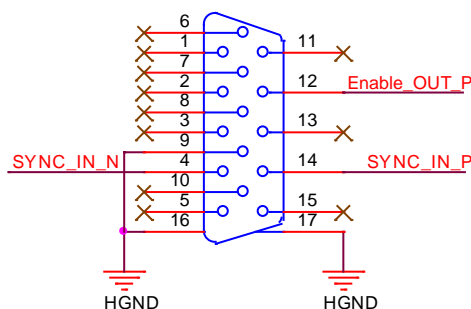

The pin definition and the corresponding relationship with the interface cable are shown in the following table:

Pin	Color	Name	I/O	Description
1	White	Reserved	/	Reserved(Do Not Connect)
2	Orange/White	Reserved	/	Reserved(Do Not Connect)
3	Black	Reserved	/	Reserved(Do Not Connect)
4	Green	Prep_IN_N	IN	HVG generator signal inform FPD to start clear process
5	Gray	Reserved	/	Reserved(Do Not Connect)
6	Brown	Reserved	/	Reserved(Do Not Connect)
7	Brown/White	Reserved	/	Reserve (Do Not Connect)
8	Blue	Reserved	/	Reserved(Do Not Connect)
9	Yellow	HVG_GND	P	Chassis ground
10	Black/White	Reserved	/	Reserve (Do Not Connect)
11	Pink	Reserved	/	Reserve (Do Not Connect)
12	Red	Enable_OUT_P	OUT	FPD generator signal to HVG indicate the clear process finished and wait for exposure
13	Light green	Reserved	/	Reserved(Do Not Connect)
14	Purple	Prep_IN_P	IN	HVG generator signal inform FPD to start clear process
15	Orange	Reserved	/	Reserved(Do Not Connect)
16	Thermal casing	Shield	P	Earth Ground

3.2.2 Interface Circuit

The schematic diagram of relevant circuits inside the control box is shown below. In which, PREP_IN_N and PREP_IN_P are PREP input signals of different types of high voltages, HGND is the reference ground, and the input and output are isolated by optical coupling. The user must choose to use one of PREP_IN_N and PREP_IN_P according to the type of the HVG.

PREP_IN_N, a switch signal corresponding to the HVG, with one end connected to HGND and one end connected to PREP_IN_N. When PREP_IN_N is not

connected to HGND, FPD detects that the signal at PREP end is low. When PREP_IN_N is connected to HGND, FPD detects that the signal at PREP is high. The HvgPrepOn parameter must be set to SignalLevel_High when the user uses PREP mode (refer to section 5.3).

PREP_IN_P, suitable for 5-24V voltage type input signal corresponding to the HVG. When the input is high, FPD detects that the signal at PREP is high. When the input is low, FPD detects that the signal at PREP is low. When the user uses PREP mode (refer to section 5.3), the HvgPrepOn parameter must be set according to the effective level of the HVG.

Enable_Out_P, an enable output signal. When OUT_EN is high, Enable_Out_P is high; When OUT_EN is low, Enable_Out_P is low. When the user uses PREP mode (refer to section 5.3), the HvgXRyEnable parameter must be set according to the valid input level required by the HVG. Please refer to appendix C for the compatible interface circuit of the Enable_Out_P according to the type of the HVG.

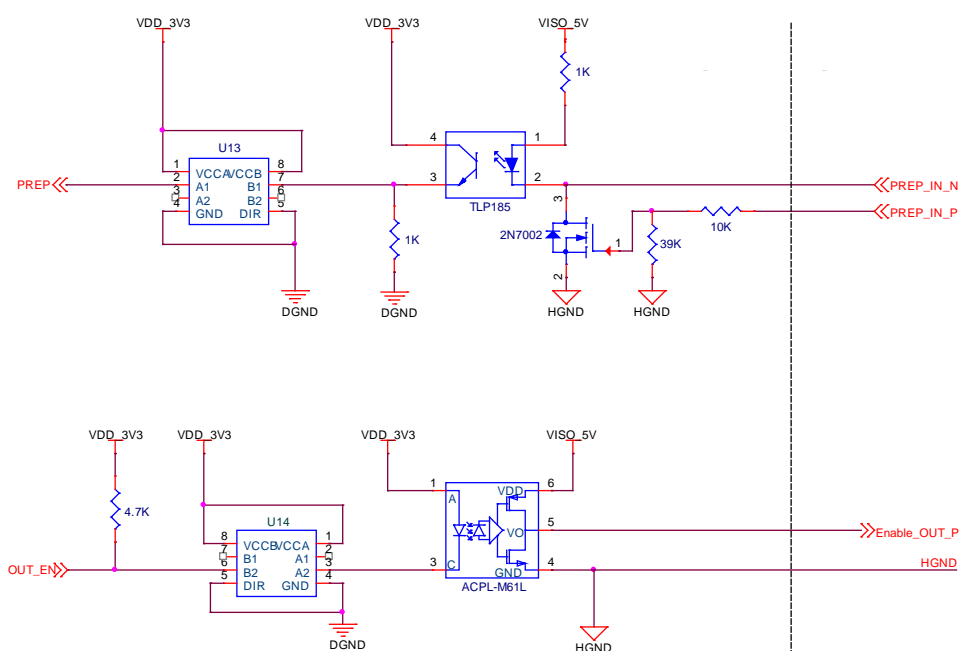

4. Software Setup

4.1 System requirement	29
4.2 Environment setup.....	29
4.3 Wired Connection	29
4.4 Software UI.....	31
4.5 List of the HAZARDOUS SITUATIONS resulting from a failure of the IT-NETWORK	48

4.1 System requirement

iDetector is developed and deployed on Windows Operation System, it can be run on Windows XP/Windows 7/Windows 8/Windows 10, OS should install latest service pack. And requires computer memory 4 GB minimum. And firewall should be shut down to avoid commuication issue.

4.2 Environment setup

Setup files and download url are included in SDK directory: Tools\env_setup

1. Please install Microsoft .NET Framework 4.5(Windows XP only can install V4.0). Download from Microsoft web site, please.
2. Visual C++ redistributed package need to be installed: vcredist_x86_2013(or vcredist_x64_vs2013).
3. For Windows XP, full path should be used in file "bind.txt" .

4.3 Wired Connection

Select wired network adapter that connected to the detector.

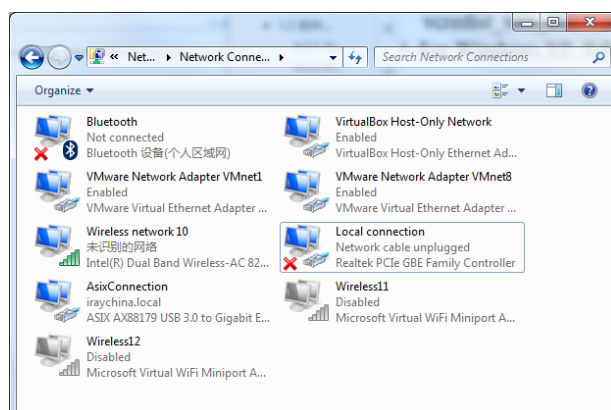

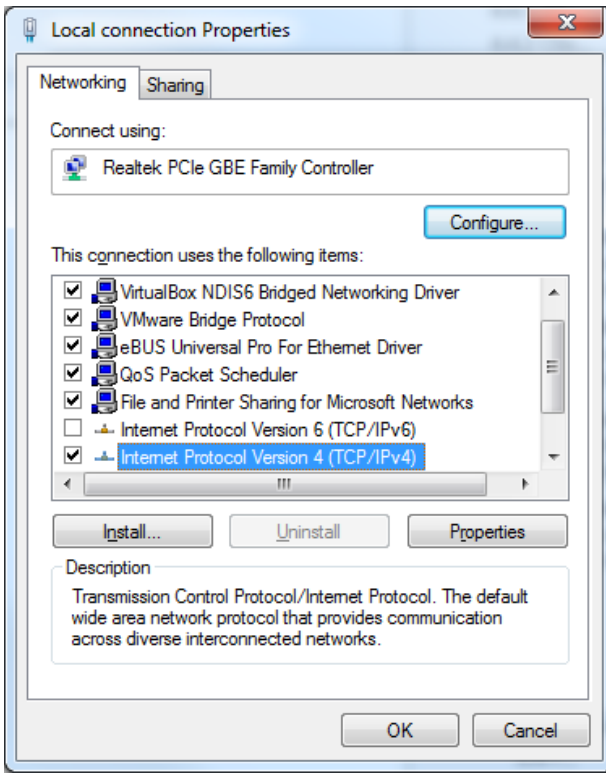
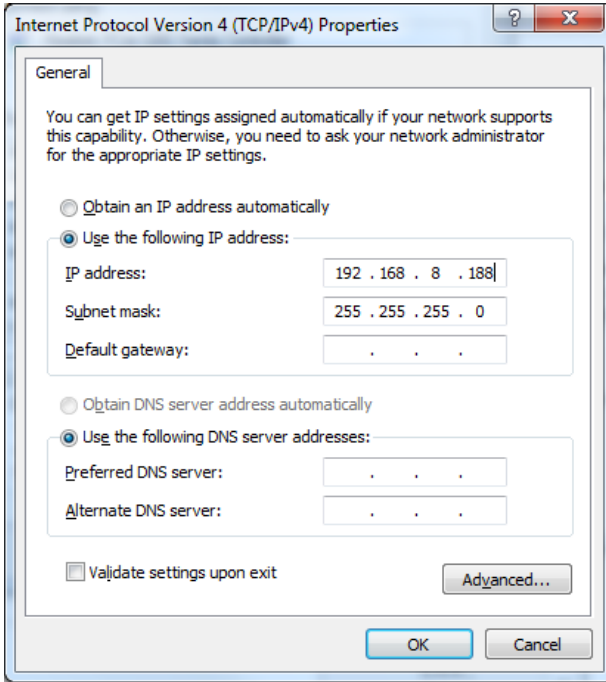
<p>Right click the network adapter. Then select properties.</p>	
<p>Double click IPV4 item Default IP settings: IP address: 192.168.8.188 Subnet mask: 255.255.255.0</p>	

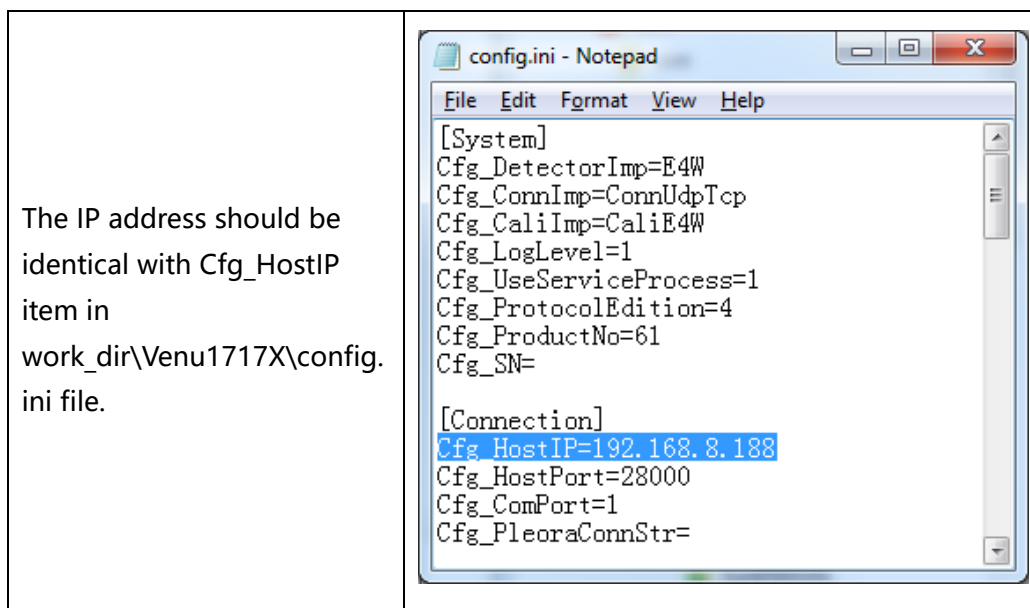

4.4 Software UI

SDK supply iDetector as tool software:

32-bits iDetector.exe: Tools\iDetector\w32

64-bits iDetector.exe: Tools\iDetector\x64

Double click iDetector.exe to run the software. For different software version, the UI maybe have little difference. If change, forgive us for not issuing a separate notice.

Tab	Function description
Home	Connect FPD and view the connect state
Acquire	Acquire image, select correction mode, save image and process image
SDK	config.ini setting, log level setting
Detector	Configure parameters for detector.
Calibrate	Generate calibration files and manage the calibration files
Local File	Open and view local images.

4.4.1 HomePage

The main function in this page is to connect detector.

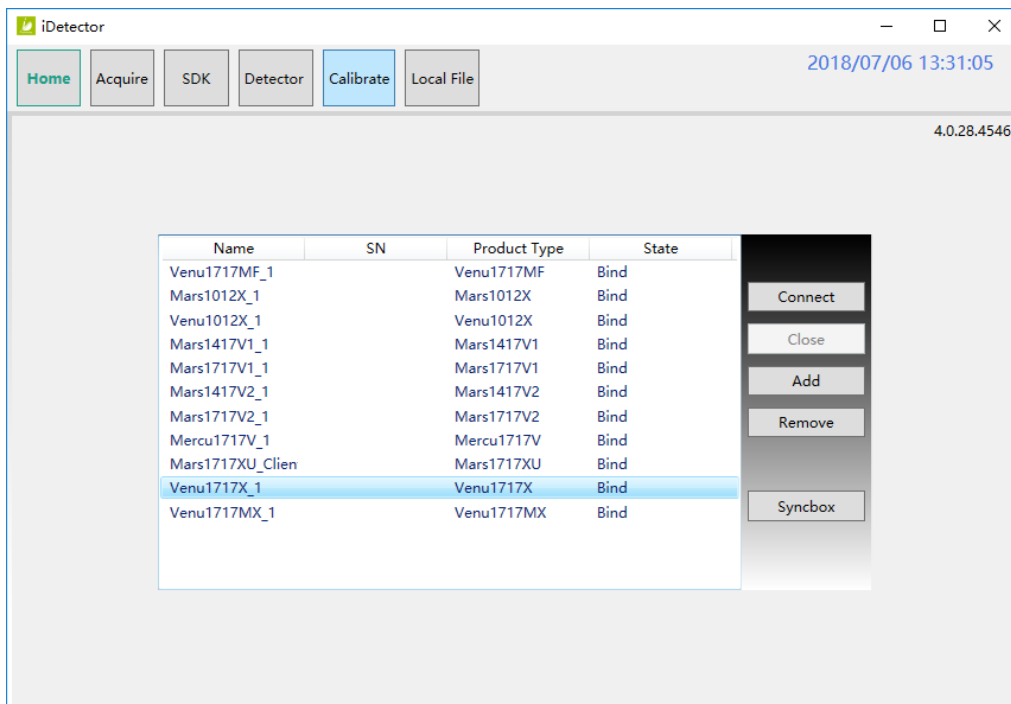

Item	Function description
Name	Display the name of detector
SN	Display the SN of detector
Product Type	Display the type of detector
State	Display the connection state (Bind, Unknown, Ready etc.)

Button	Function description
Connect	Click this button to connect the selected detector.
Close	Click this button to disconnect the selected detector.
Add	Add work directory
Remove	Remove work directory
Syncbox	Open Syncbox configuration window(Optional device)

4.4.2 Acquire Page

This page is used to acquire image under different work mode, and user can choose correction mode too. When acquire image finished there will be a preview image shown on the screen. The properties of image is displayed on the left of preview image. And on the right of preview image there is a list to show thumbnail of images. User can select it and double click to see for detail. User can rotate, reverse or mirror image. User can get the value of AVG and SNR by ROI tool. The acquired images can be save as raw, tiff or dicom formats. Both raw and tiff formats support single frame and continuous frames save.

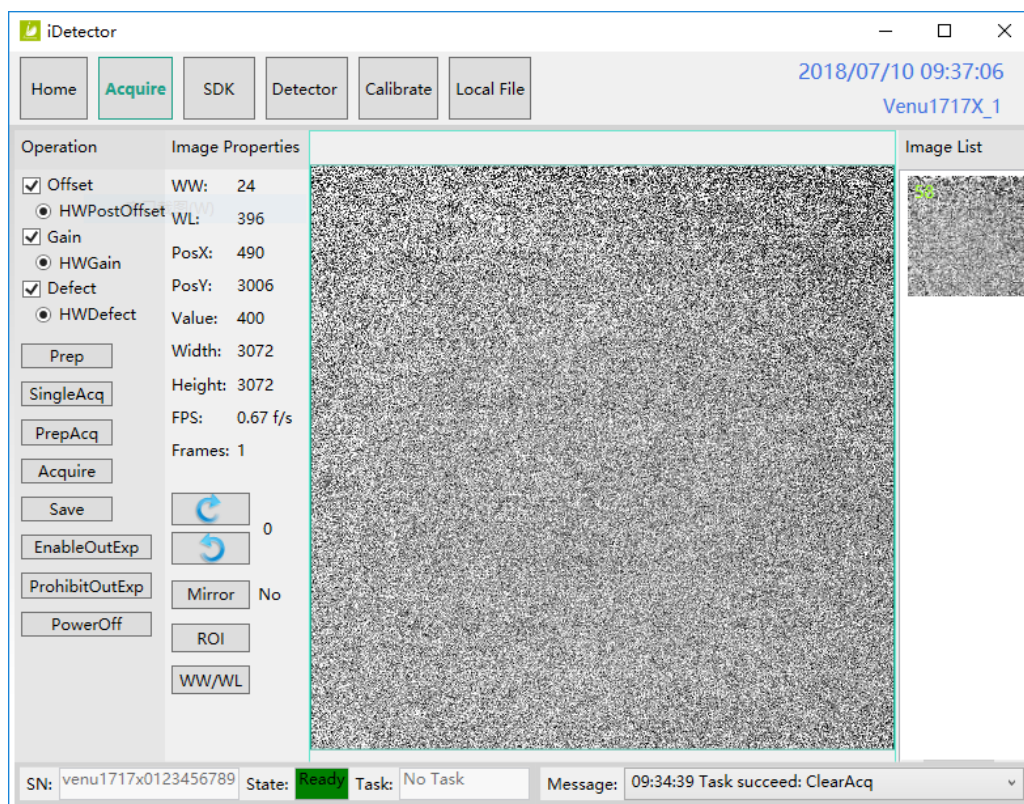



Status bar shows detector' s serial number, the current task and state of detector, and feedback information of command. Status bar is also can be seen in other pages, and they are all same.

Item	Description
SN	SN number of current connected detectors
State	Detectors state , eg busy, ready
Task	the current task of detector
Message	feedback information of command, eg succeed, failed

Functions in this Page.

Correction Menu		Description
Offset	HWPPostOffset	Do hardware PostOffset correction for image if checked(Only for Mars detector)
Gain	HWGain	Do hardware Gain correction for image if selected
Defect	HWDefect	Do hardware defect correction for image if checked(for Mars and Mercu detector)
Acquire Button		Description
Prep		Clear. Prepare to integrate.
SingleAcq		Acquire once
PrepAcq		Clear and acquire
Acquire		Series acquire images

Save	Save image, the format is raw and tiff
EnableOutExp	Allow outer trigger
ProhibitOutExp	Disable outer trigger
Poweroff	shutdown detector
Image Properties& Image Process	Description
WW	window width
WL	window level
PosX	X coordinates of the current cursor at the point
PosY	Y coordinates of the current cursor at the point
Value	Value of the current cursor at the point
Width	Image width
Height	Image height
FPS	Frame rate
Frames	Display the frame count
	Rotate the image clockwise, 90 degrees every time.
	Rotate the image anticlockwise, 90 degrees every time.
Mirror	Open or close mirror
ROI	ROI tool, to view the image of the AVG, SV, SNR and other parameters. Press "ctrl" key, can create several ROI area.
WW/WL	Auto adjust WW/WL based on selected area by right button of mouse.
Image List	Show thumbnails

When the image is displayed on the screen, maybe the user want to see details by dragging or zoom in/out the image, for convenience, these are some shortcuts.

1. Click the left mouse button: movie playback function operation area display.
2. Double-click the left mouse button: the image display in center and with maximum size;
3. Double-click the right mouse button: restore the window level and width for WL:32767/WW:65535;
4. Drag the left mouse button to drag the image display;
5. Lateral-drag the right mouse button to adjust the window width, and vertical-drag the right mouse button to adjust the window level;
6. F3 Key: Quickly locate the image window width and window level.

- F4 Key: Adjust window width and window level automatically.

4.4.3 SDK Page

SDK page is used to set parameters in config.ini and log level.

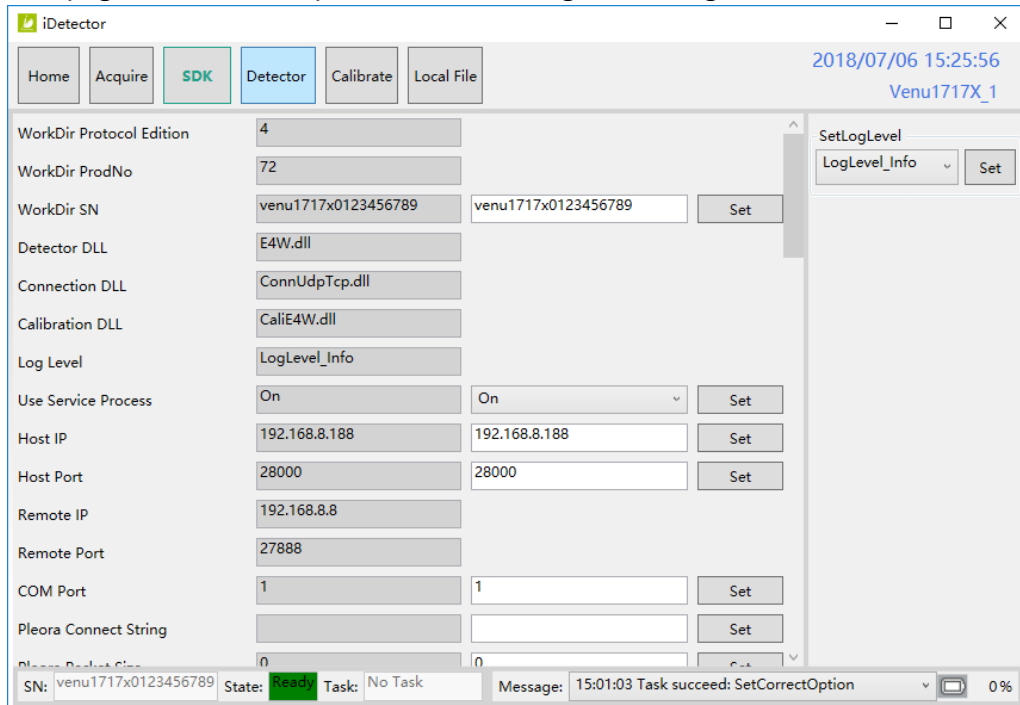

4.4.4 Detector Page

In this page, there are Parameters, Sensor and Images tab.

- **Parameters**

- Enter Detector page, the tab of Parameters is activity by default. There are 5 regions in this page.
- Parameter name region: lists the parameters.
- Parameter read region: read the parameters, the values of the parameters are displayed in this area by Read.
- Parameter write region: write parameter. Entered value of the corresponding parameter in this area can be write to detector.
- Operation region: functional operation buttons area.
- Status bar region: status bar for detector state and information of reading or writing parameters, etc.

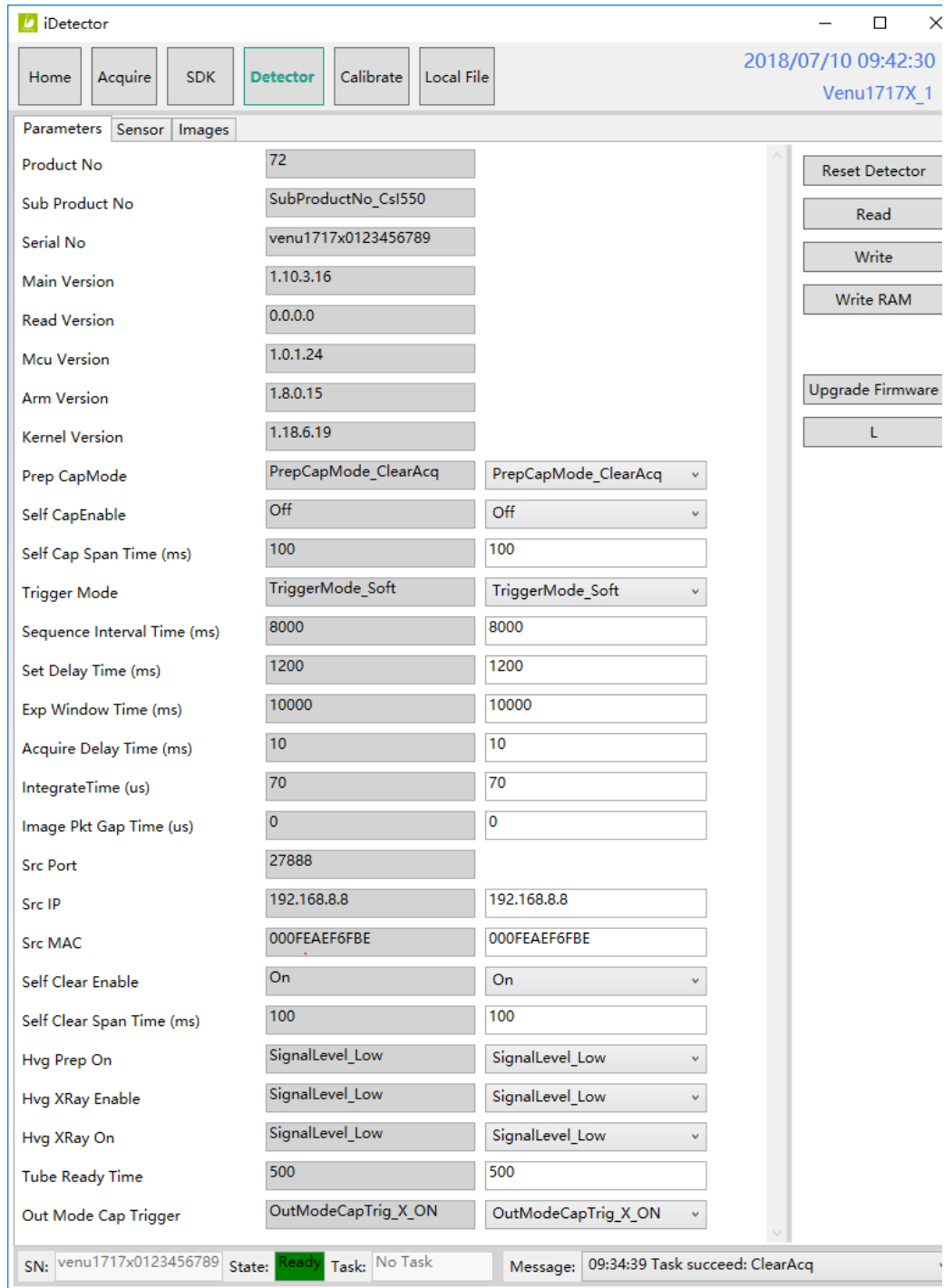

Configuration parameters description as below:

Name	Description	modifiable
Product No.	Type of detector product	N
Sub Product No.	Sub type of detector product	N
Main Version	Version number of the detector Main	N
Read Version	Version number of the detector	N

	Read	
Mcu Version	Version number of MCU	N
Arm Version	Version number of ARM App	N
Kernel Version	Version number of ARM Kernel	N
Prep CapMode	PrepCapMode_ClearAcq. Do not modify	N
Self CapEnable	N/A. Do not modify	N
Self Cap Span Time	N/A. Do not modify	N
Trigger Mode	Software. Do not modify	Y
SequenceIntervalTime(ms)	Interval time for sequence acquire	Y
Set Delay Time(ms)	Set delay time	Y
Exp Window Time(ms)	Exposure window time	Y
Acquire Dleay Time(ms)	N/A. Do not modify	N
Integrate Time(us)	N/A. Do not modify	N
Image Pkt Gap Time(us)	N/A. Do not modify	N
Src Port	Detector port	N
Src IP	Detector IP	Y
Src MAC	Detector MAC	Y
Self Clear Enable	Self clear. Close by default	Y
Self Clear Span Time(ms)	Self clear span time	Y
Hvg Prep On	PREP electrical level setting	Y
Hvg Xray Enable	Enable electrical level setting	Y
Hvg Xray On	N/A. Do not modify	N
Tube Ready Time	Tube ready time	Y
Out mode cap trigger	N/A. Do not modify	N

Button function description:

Function Button	Description
Reset Detector	Reset Detector
Read	Read parameters
Write	Write parameters
Write RAM	Write parameters into RAM(will lost changes after reset)
Upgrade Firmware	Upgrade firmware
L	Upload detector log

- **Sensor**

The mainly function in this page is to probe the temperature and humidity of the detector. Click “Read” button to get the value of the temperature or humidity.



Sensor type	Explanation
Temperature	Read detector temperature
Humidity	Read detector humidity

- **Images**

You can Query and upload Images from detector to Workstation.

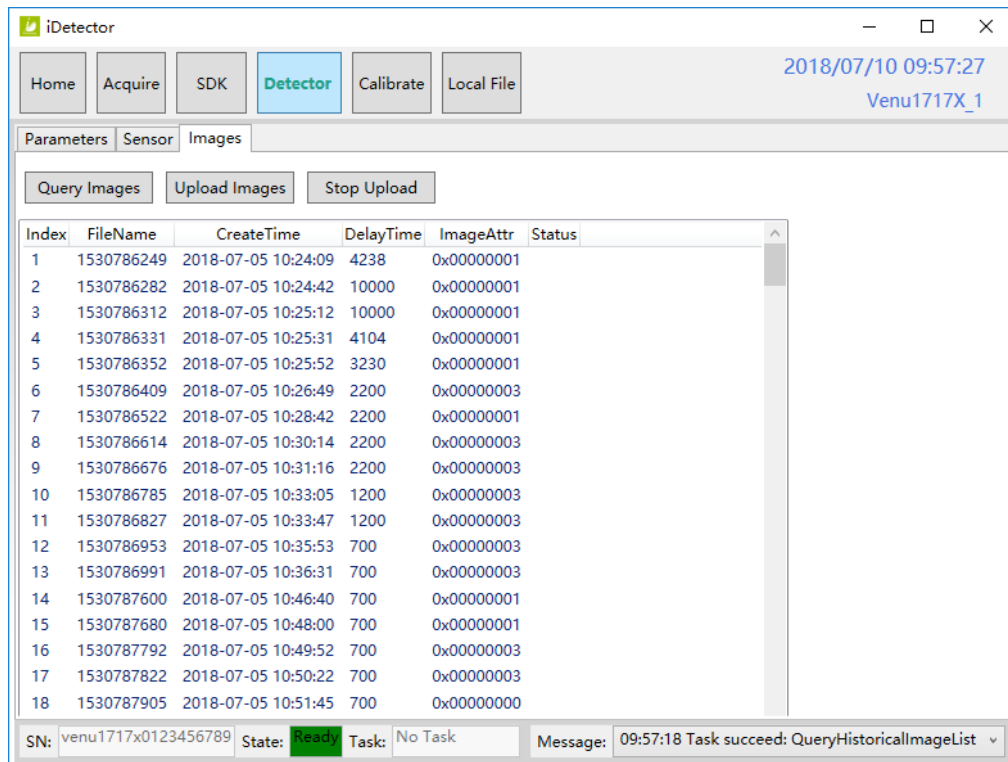

4.4.5 Calibrate Page

Offset, Gain, Defect calibrate files can be generated and managed in this page.



Click "Start Generate Templates" to enter generating templates page.

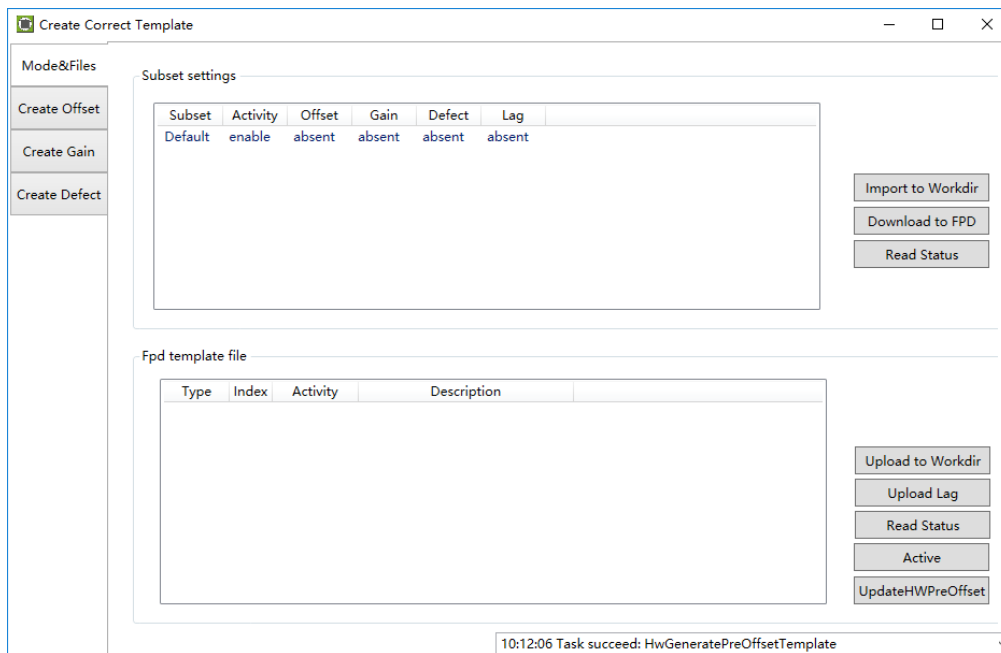

SubTab	Description
Mode&Files	Manage template files
Create Offset	Create Offset template
Create Gain	Create Gain template
Create Defect	Create Defect template

Mode&Files page	Description
Import to Workdir	Copy template file into current calibration directory.
Download to FPD	Select one item first. Then click this button to download selected template file(s) into detector.
UpLoad to Workdir	Select one item in Fpd template file control and select one item in Subset settings control. Click this button to upload selected template from detector into specified calibration directory.
Upload Lag	Upload Lag into SDK current directory
Active	Select one item in list. Click this button to activate selected template.
UpdateHWPreOffset	Force detector update Offset template(Unneeded generally)
ReadStatus	refresh list.

- **Update hardware Pre-Offset Template File**
 1. Enter Acquire interface, select HWPostOffset option

2. Enter Calibrate interface, click UpdateHWPreOffset button. Waiting until status bar displayed: "Task succeed: HwGeneratePreOffsetTemplate"

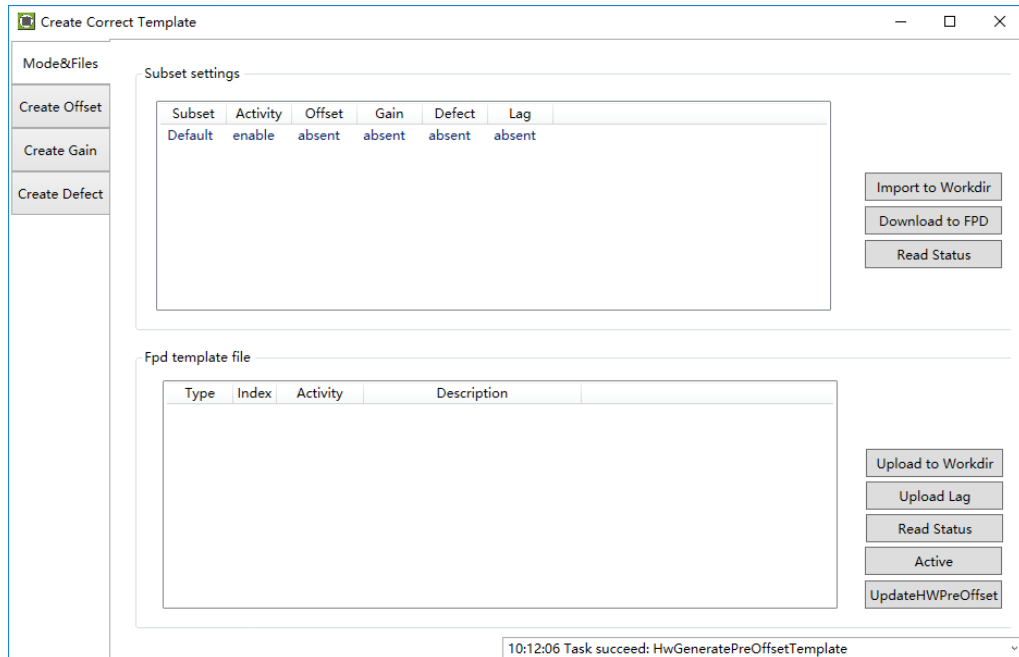

- **Generate Gain Template File**

If the relative position between tube and detector changed or KV value changed, it suggest to create gain template file.

1. Enter Create Gain page

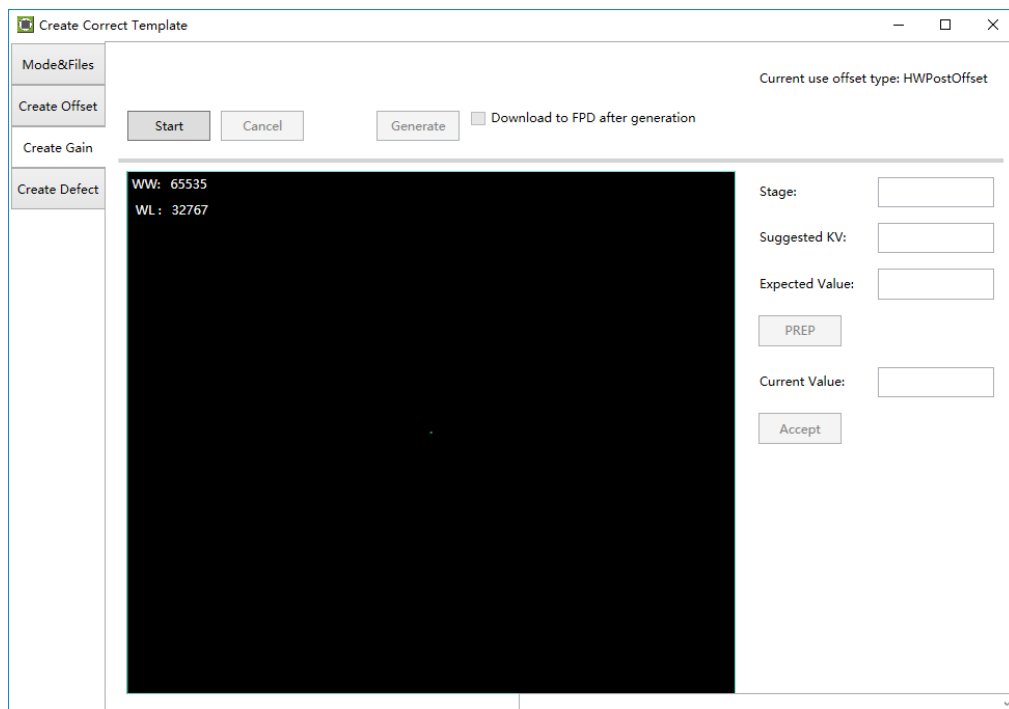

2. Click "Start" button to start process.

3. Click PREP button, acquire image. Please exposure after Acquire button enable. And click Acquire button to acquire image after exposure end. Click Accept button after acquired image. If Current Value textbox is yellow, click PREP button. Re-acquire images after adjust generator parameters.
Note: In different trigger mode, the operation maybe have little difference. Please follow the UI tips.

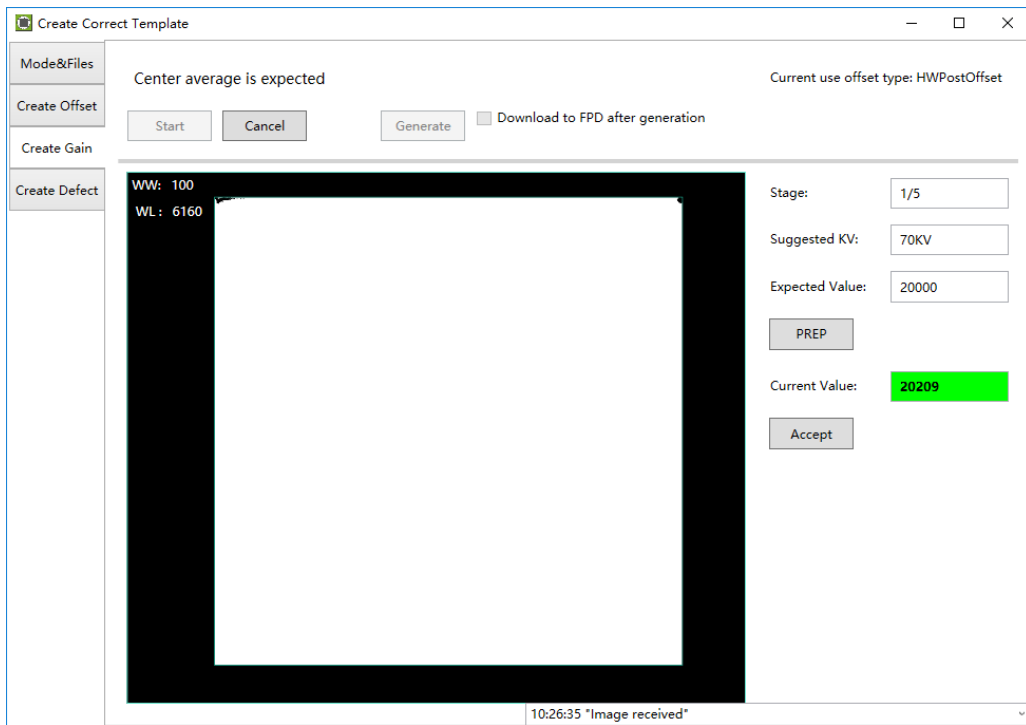

4. Create gain template need several images. You can click Generate button to generate Gain template once one image was captured. But it may lead to imperfect template quantity.

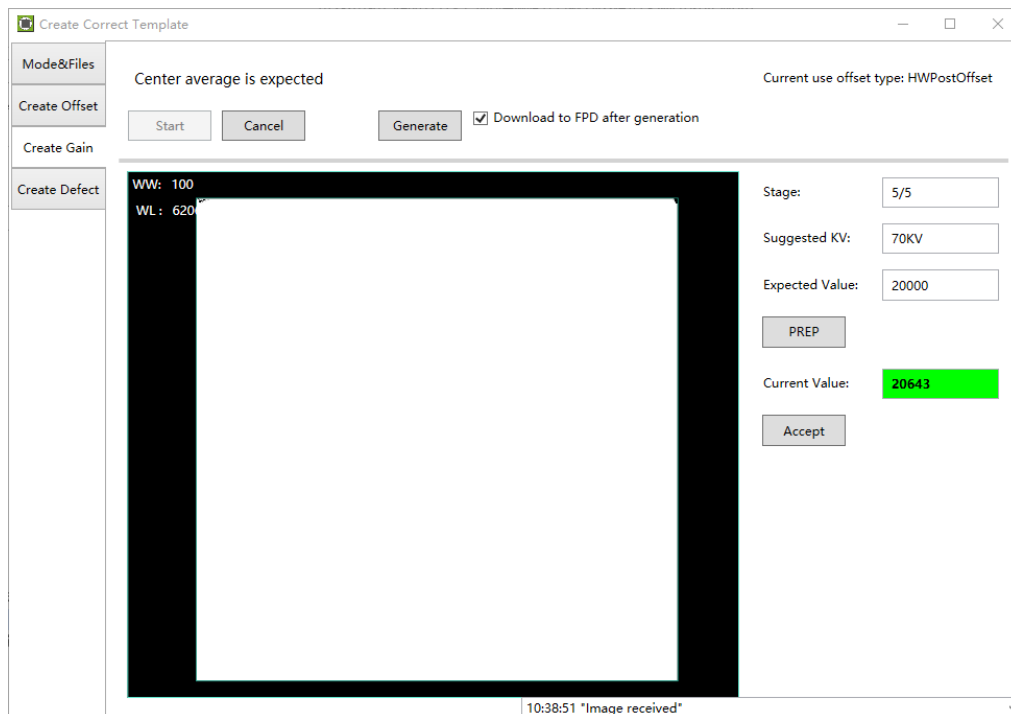

5. Download template file dialog will pop up if "Download to FPD after generation" option was checked. Click Download button to download the template into the detector.

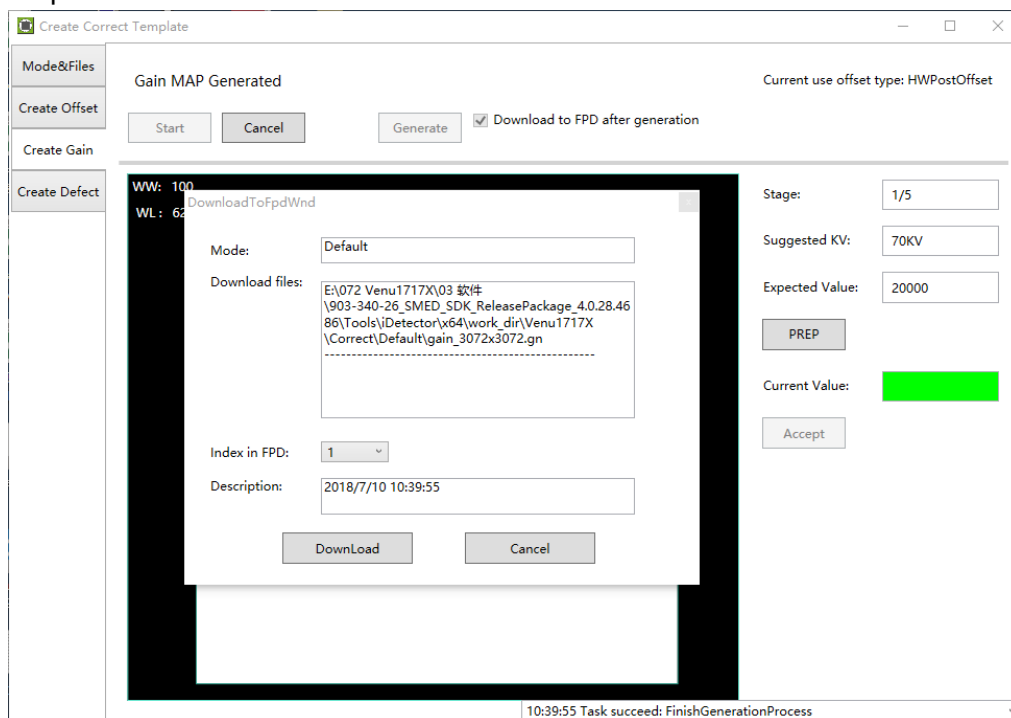

6. Select Mode&Files tab. Click Read Status button to check whether just downloaded gain template is enable. If not, please click Active button to enable.

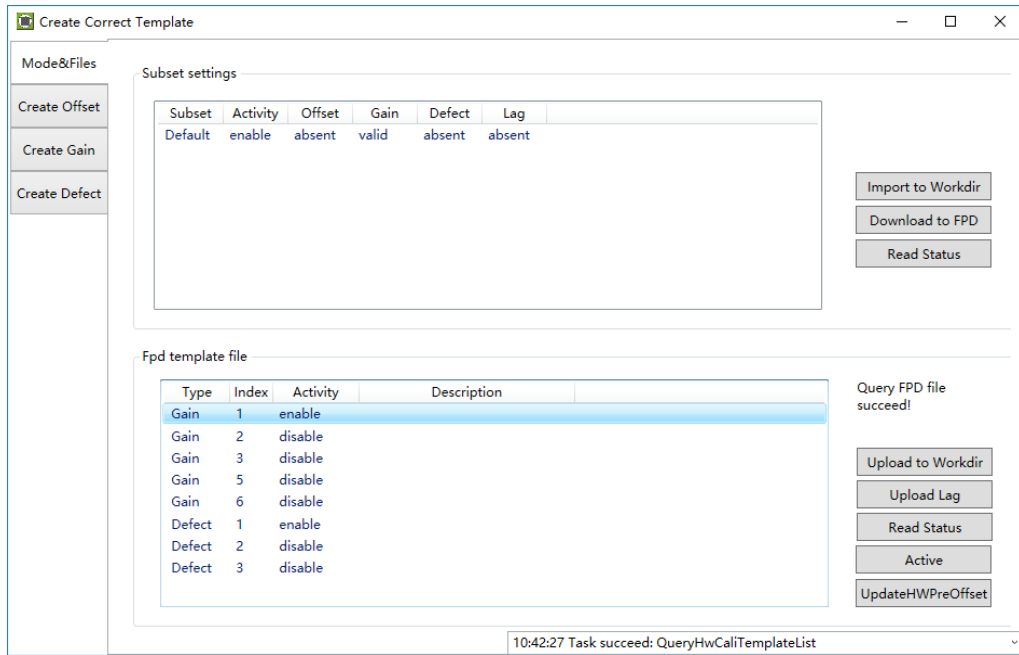

- **Generate Defect Template File**

If there are new defect(s) or bad line(s) on image, it suggest to update defect template.

Generate defect template steps as below:

1. Enter Acquire UI. Choose HWPostOffset.
2. Enter Calibrate UI. Select Create Defect tab.

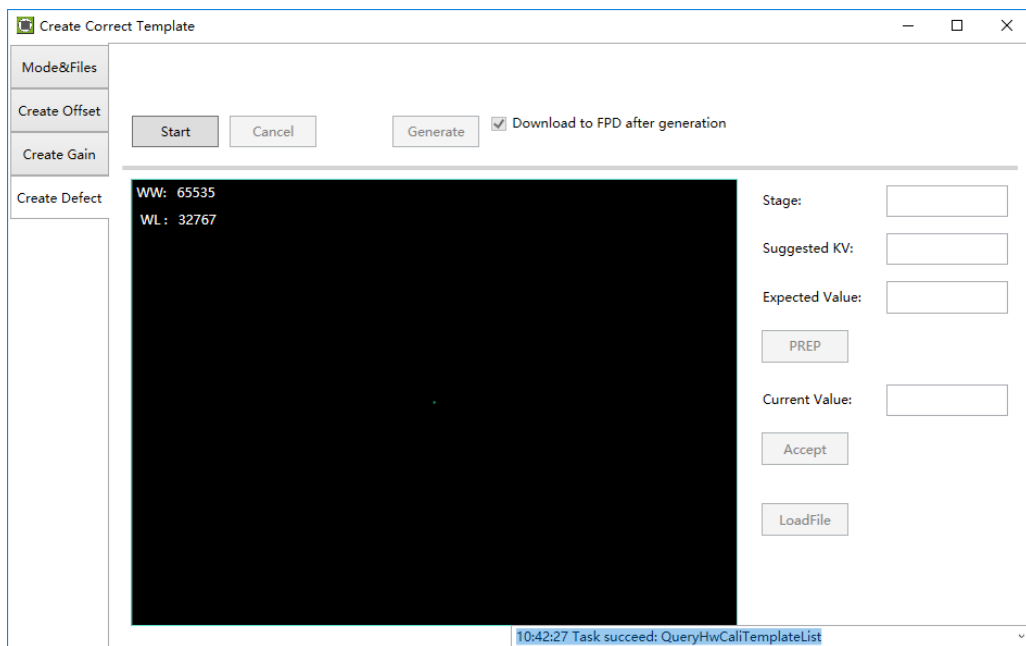

3. Click "Start" button to start process.
4. Click PREP button, acquire image. Please exposure after Acquire button enable. And click Acquire button to acquire image after exposure end. Click

Accept button after acquired image. If Current Value textbox is yellow , click PREP button. Re-acquire images after adjust generator parameters.

Note: In different trigger mode, the operation maybe have little difference.

Please follow the UI tips.

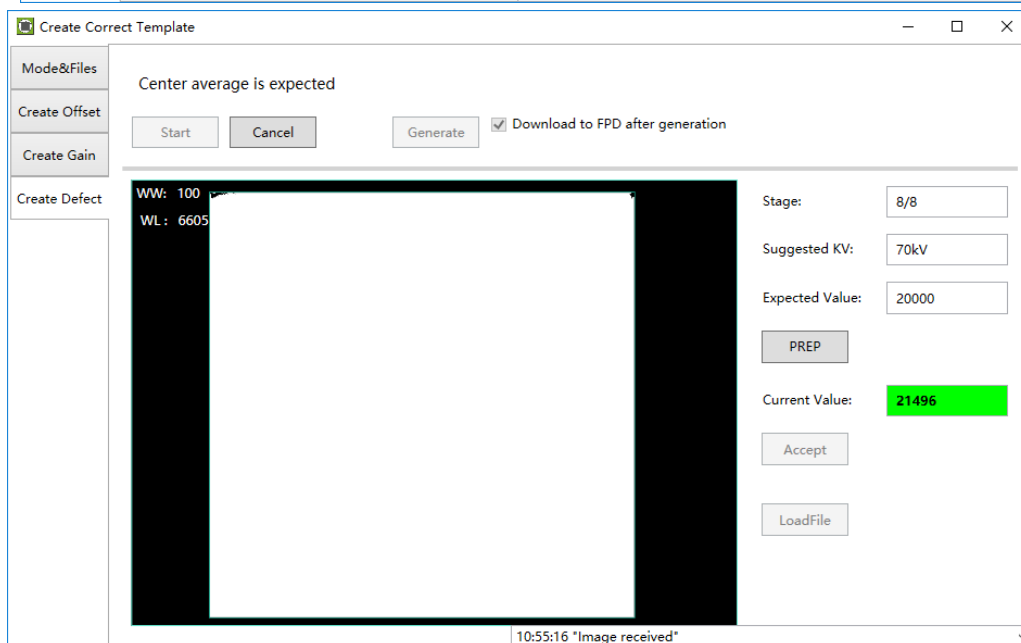
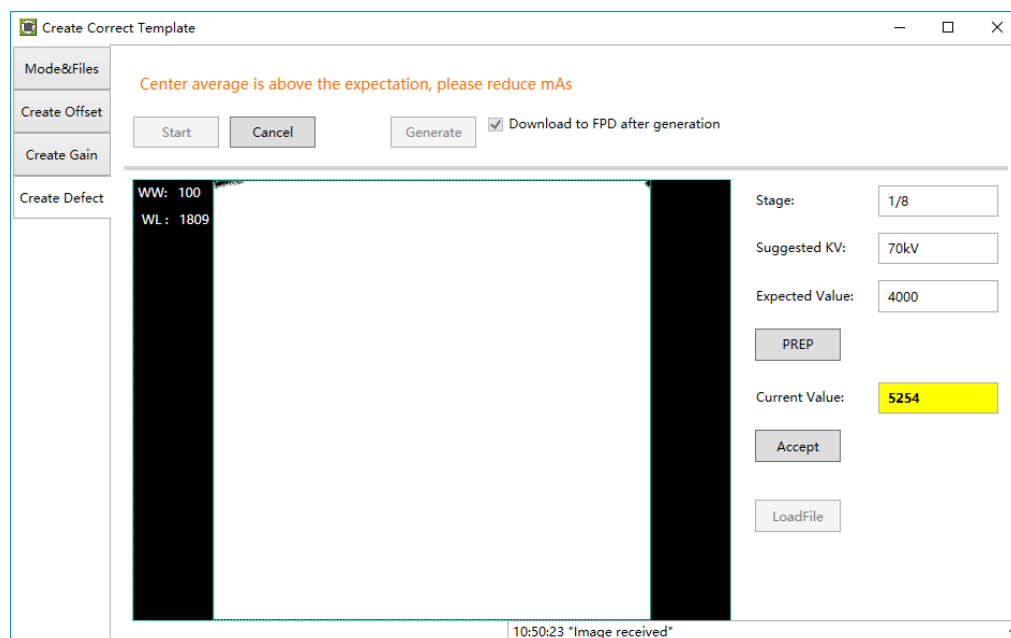

5. You can click Generate button to generate Gain template after acquired required images.

6. Download template file dialog will pop up if "Download to FPD after generation" option was checked. Click Download button to download the template into the detector.

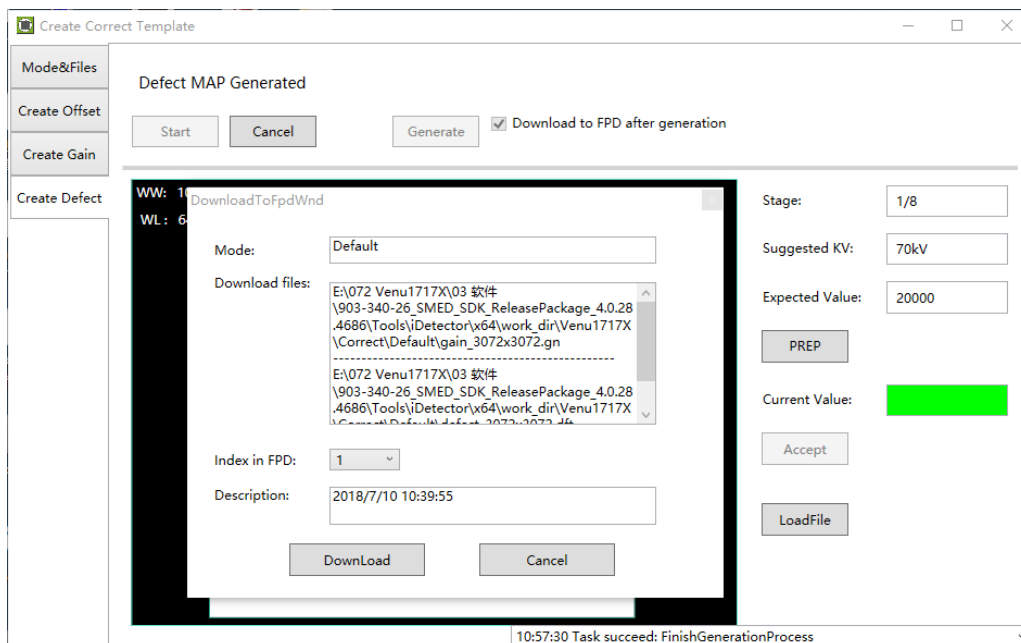

7. Select Mode&Files tab. Click Read Status button to check whether just downloaded gain template is enable. If not, please click Active button to enable.

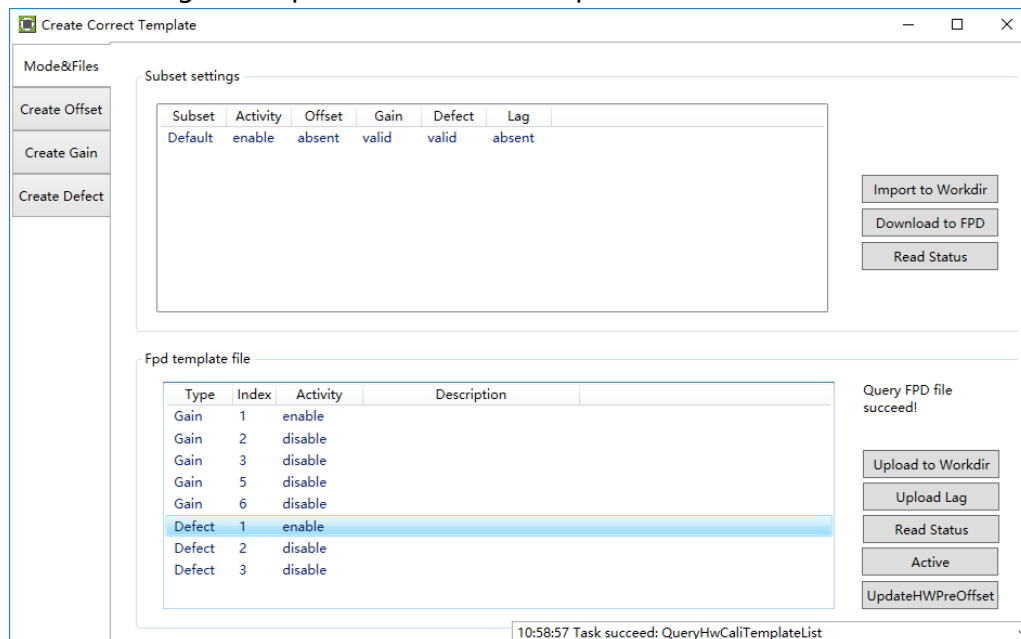

4.4.6 Local Page

In this page user can open the image files saved in local, the file formate can be raw, tiff, dft. When the software is disconnected to detector, the file still can be opened.

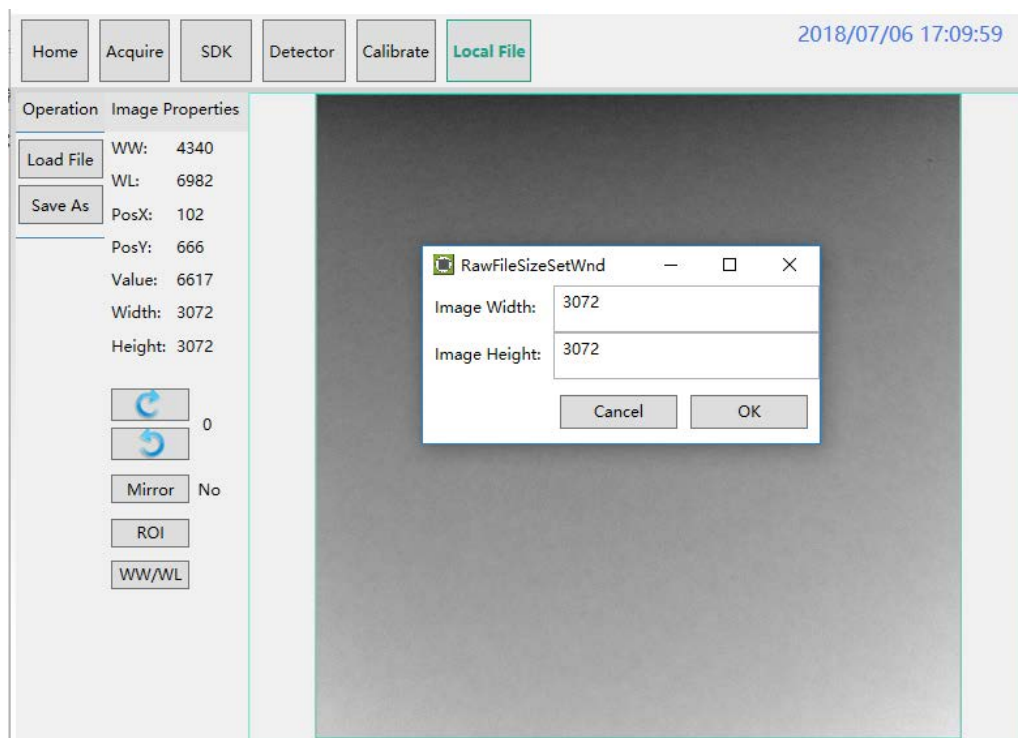

Click "Load File" , there will be an open file wizard. Select file and click open or double click the file. The tiff file will be opened directly. For the raw file or dft file there will be a dialog to select image size. Select correct size to open image files. If the file is not correct user will get an error message.

Venu1717X image size: 3072*3072



This page provides ROI tool, which can see the AVG, SNR, and other properties of the chosen image area by right mouse button.

This page provides WW/WL tool as Acquire page . Click this button to auto adjust WW/WL based on selected area by right button of mouse.

Image Properties& Image Process	Description
WW	window width
WL	window level
PosX	X coordinates of the current cursor at the point
PosY	Y coordinates of the current cursor at the point
Value	Value of the current cursor at the point
Width	Image width
Height	Image height
	Rotate the image clockwise, 90 degrees every time.
	Rotate the image anticlockwise, 90 degrees every time.
Mirror	Open or close mirror
ROI	ROI tool, to view the image of the AVG, SV, SNR and other parameters. Press "ctrl" key, can create several ROI area.
WW/WL	Auto adjust WW/WL based on selected area by right button of mouse.

4.5 List of the HAZARDOUS SITUATIONS resulting from a failure of the IT-NETWORK

- a) The operating system is not compatibility;
- b) Change or update the software failed;
- c) The compatibility of the interface;
- d) The data transfer protocol error;
- e) The inconsistent of interface or format leads to data distortion;
- f) The data output failed;

5. Operation Instructions for Image Acquisition

5.1	<i>Steps for acquiring image</i>	50
5.2	<i>Software Mode</i>	50
5.3	<i>Prep Mode</i>	52
5.4	<i>FreeSync Mode</i>	54
5.5	<i>Inner Mode</i>	55
5.6	<i>After use</i>	57

Venu1717X provides SDK for users to integrate detector into their DR system. Additionally, it also provides an application for demonstration, i.e. IDetector. User can use IDetector to control detector without DR system.

Reference:

903-341-13_SDK_ProgrammingGuide_EN_A3.pdf

903-341-14_iDetector_UserManual_EN_A3.pdf

5.1 Steps for acquiring image

- Make sure the hardware is connected correctly and then power on. Once powered off, please wait at least 60s before power on again
- Wait until initialization is complete
- Connect the software
- choose the synchronization mode
- Generate HWPreOffset, Gain and Defect template after the detector reaches thermal equilibrium
- Acquire images in the selected mode

To Acquire X-ray image is the main operation of Venu717X. Most importantly, detector should build synchronization with X-ray generator. Venu1717X has four synchronization modes to acquire X-ray image, which is Software Mode, Prep Mode, FreeSync Mode and Inner Mode.

5.2 Software Mode

5.2.1 Block Diagram

Software mode is the basic way to acquire X-ray image. Please see figure below for general feature. Workstation is a host PC device installed with iDetector and SDK. FPD is the Flat Panel Detector and HVG is the High Voltage Generator. In this mode, Workstation does not have to control X-ray generator. Users would decide when to shoot X-ray.

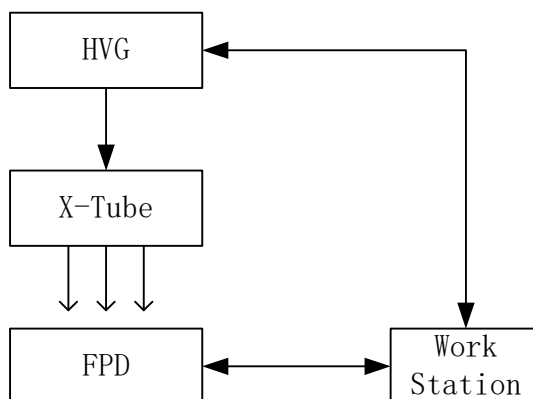

5.2.2 Work Flow

选择 HWPostOffset、HWGain、HWDefect.

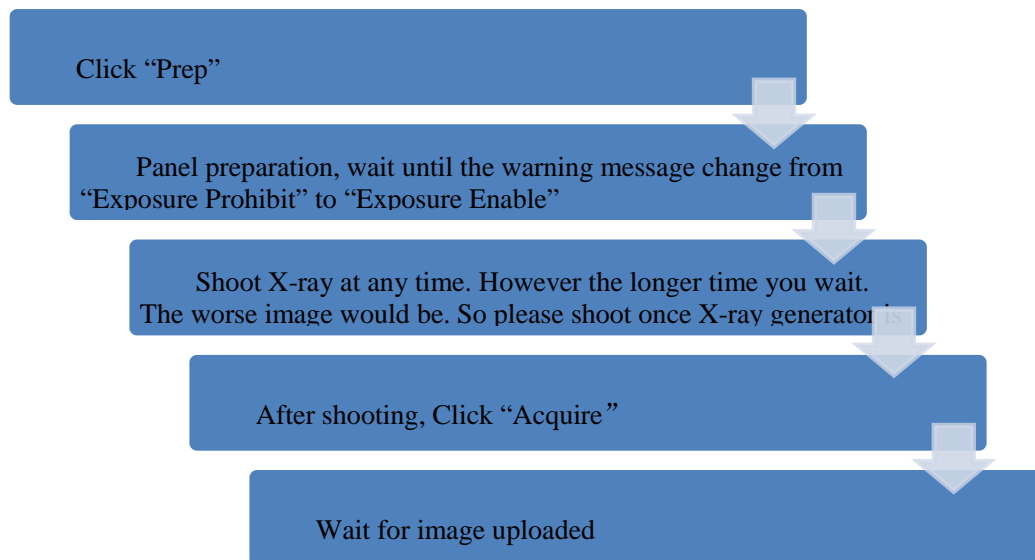

5.2.3 Timing Setting

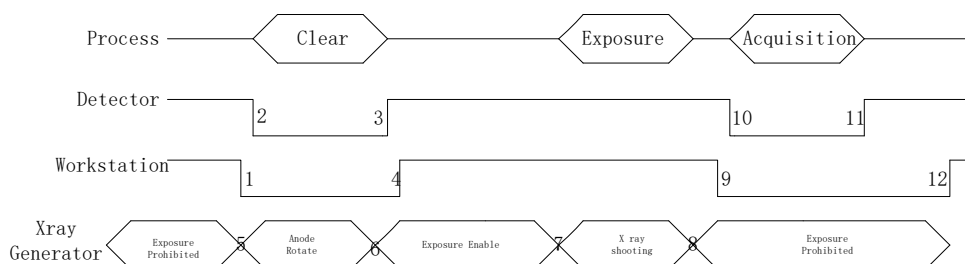

1. Workstation receives "prep" request, send command "Clear" to panel.
2. Panel receives "clear" from workstation, start detector internal clear cycle. At the same time, detector would tell workstation "Exposure Prohibited" .
3. Detector finished " Clear" action and send a message reminding "Exposure Enable"
4. Workstation shows "Exposure Enable" on the IDetector' s message bar to tell user shoot X-ray now.
5. User triggers X-ray generator to initialize and do anode rotation to prepare for X-ray shooting.
6. X-ray generator finishes preparation for X-ray shooting and reminds user to shoot.
7. X-ray generator starts releasing X-ray
8. X-ray generator finishes X-ray shooting.
9. Workstation receives "Acquire" request, send command "Data Acquisition" to panel.

10. Panel receives "Data Acquisition" from workstation, start data acquisition operation.
11. Panel completes image acquisition and begins to send data to workstation.
12. Workstation receives all image data from panel.

If Hardware Pre-offset and Hardware calibration is selected, image is the final image.

If Hardware Post offset and Hardware calibration is selected, image got would be preview image (2x2 binning). After step12, panel would do another dark image acquisition. With both light image and dark image, panel completes all the correction and calibration process. Finally, panel uploads processed image to workstation.

5.3 Prep Mode

5.3.1 Block Diagram

Prep Mode is one kinds of outer synchronization mode with generator. At this mode, generator only output one x-ray preparing signal to detector, then detector can synchronous the x-ray enable signal with generator and acquisition the image. What' s more, the Prep signal valid level can be set high or low level to applied more requirements of generator interface.

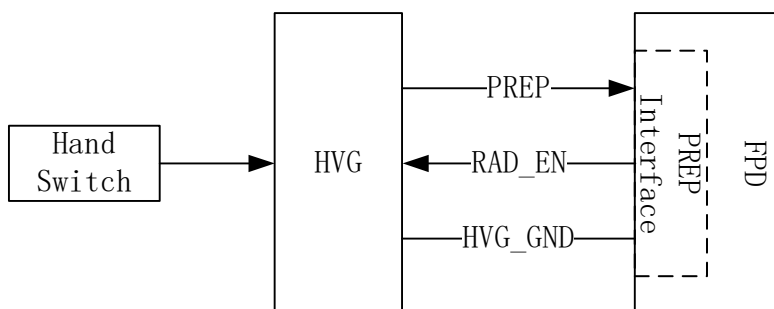

5.3.2 Work Flow

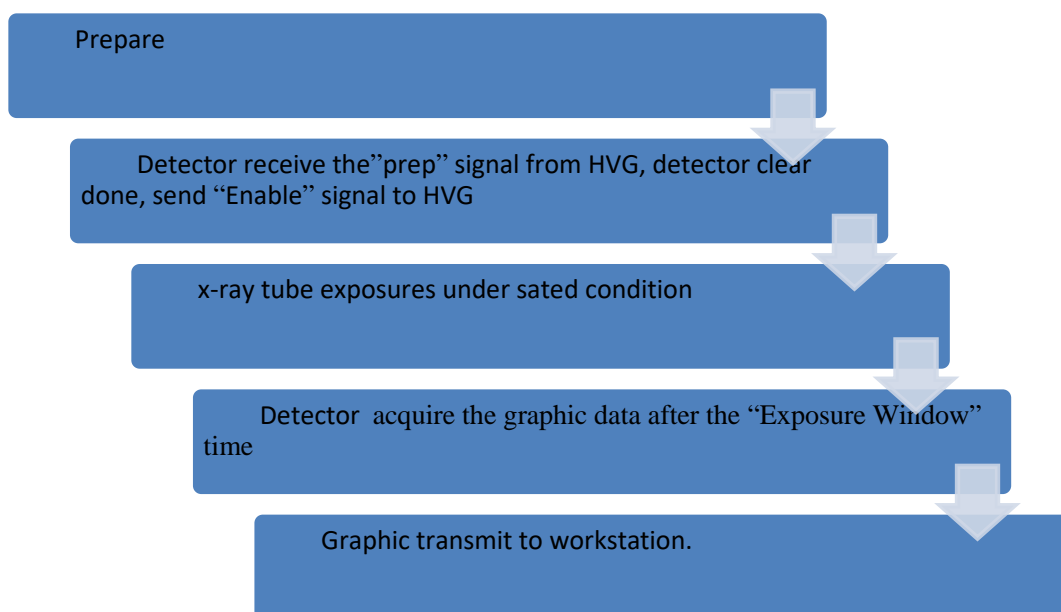

5.3.3 Timing Setting

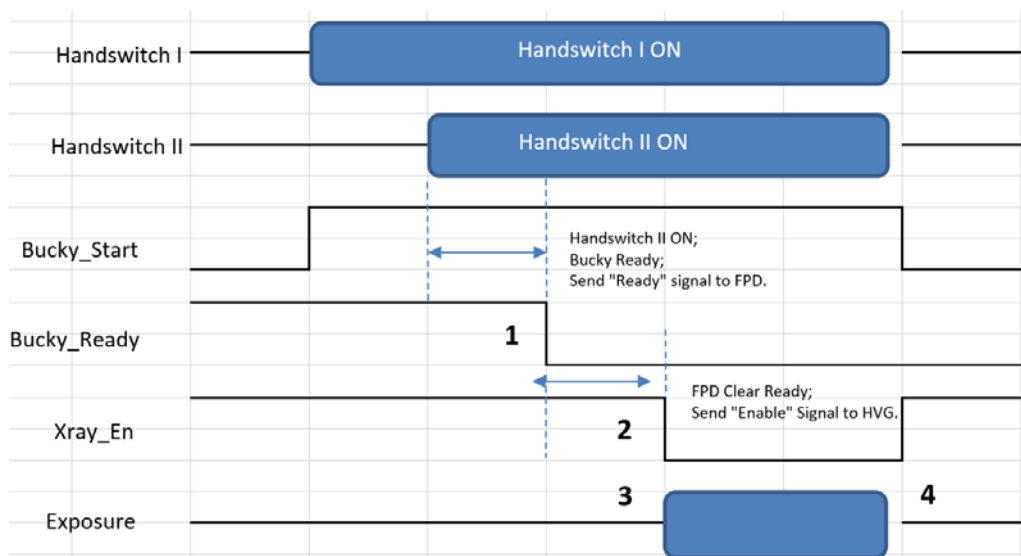

1. DR system triggers the Bucky_Start/ Prep signal to detector. Then detector can do preparing process for exposure, meanwhile detector should output the exposure inhibit signal.
2. When detector preparing done and in ready status, it send "Enable" signal to system. And the x-ray window will open for exposure.
3. System exposure done.
4. After x-ray window finished, detector can acquire the light image and transmit to PC.

5.4 FreeSync Mode

5.4.1 Block Diagram

Workstation is a host PC device installed with iDetector and SDK. In this mode, user doesn't interact with Workstation. After shooting, images would be shown on screen immediately.

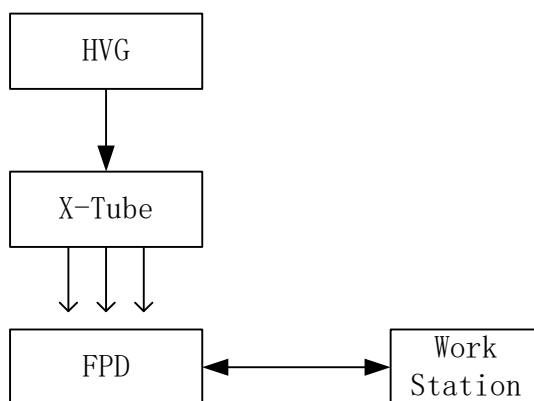

5.4.2 Work Flow

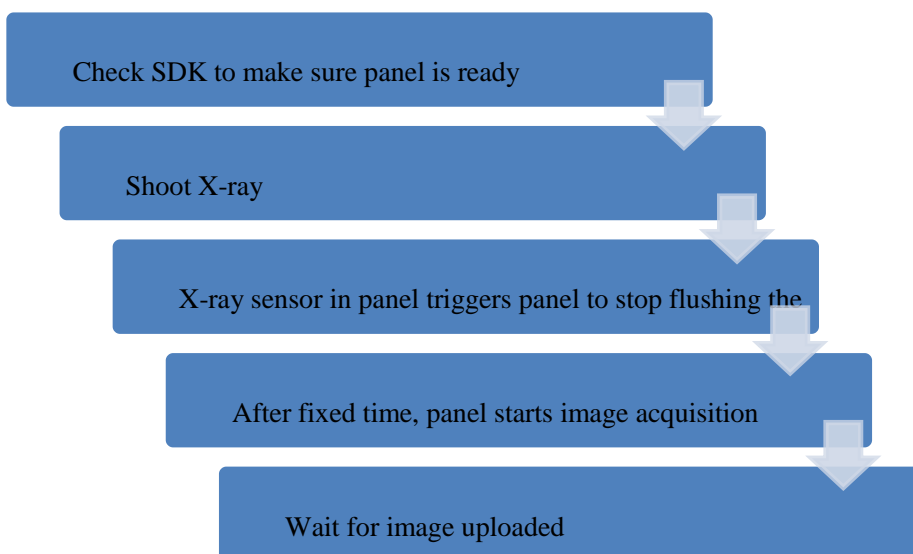

5.4.3 Timing Setting

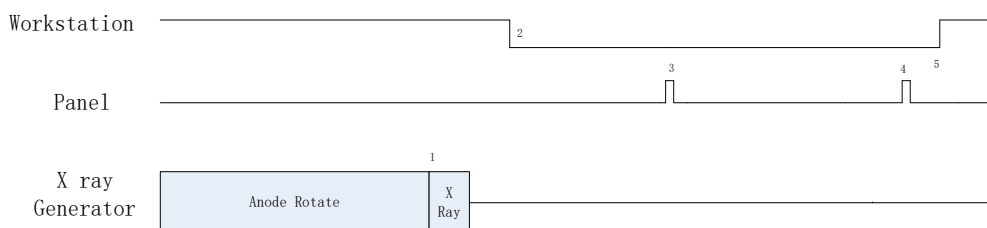

1. X-ray generator is ready for X-ray shooting and begins to release X-ray.

2. Workstation receives "Exposure Prohibited" from Panel.
3. Panel starts uploading preview image to Workstation. If hardware offset is selected, panel would do offset first, and then upload preview image (2X2 binning).
4. Panel starts uploading Post-dark image to Workstation. If hardware offset is chosen, panel would do correction and calibration first, then upload processed image to Workstation.
5. Workstation receives "Exposure Enable" from Panel.

5.5 Inner Mode

5.5.1 Block Diagram

Workstation is a host PC device installed with iDetector and SDK. In this mode, workstation does not control X-ray generator. Users would decide when to shoot X-ray.

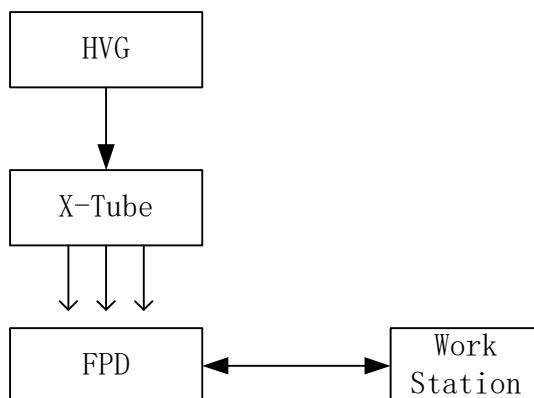

5.5.2 Work Flow

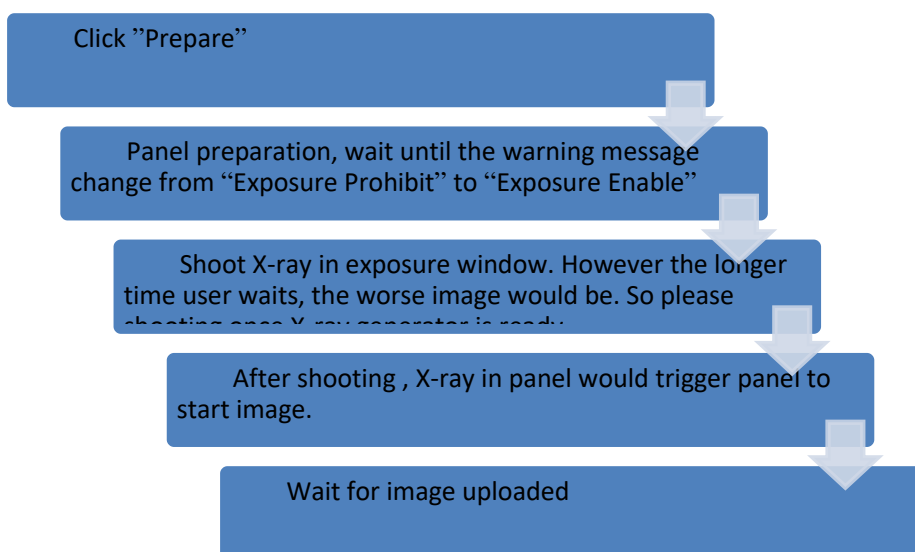

5.5.3 Timing Setting

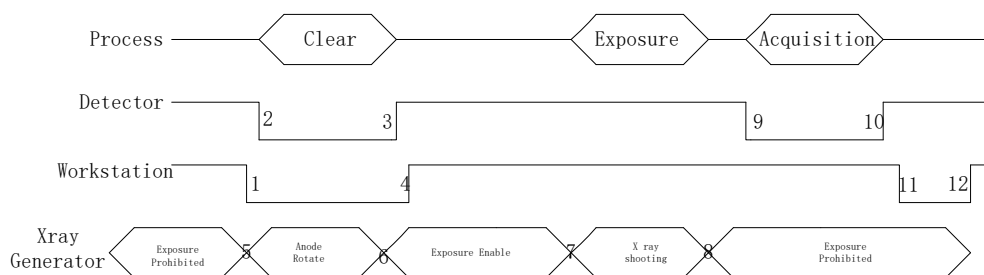

1. Workstation receives "prep" request and sends "Clear" to panels.
2. Panel receives "clear" from Workstation, start clear operation. Meanwhile, panel would send "Exposure Prohibited" to Workstation.
3. Panel finishes "Clear" operation and send "Exposure Enable" to Workstation.
4. Workstation shows "Exposure Enable" on the IDetector' s message bar to tell user shoot X-ray.
5. User triggers X-ray generator to initialize and do anode rotation to prepare for X-ray shooting
6. X-ray generator finishes preparation and reminds users.
7. X-ray generator begins releasing X-ray
8. X-ray generator finishes X-ray shooting.
9. X-ray sensor in panel triggers panel to start image acquisition operation.
10. Panel completes image acquisition and begins to send data to Workstation.
11. Workstation starts receiving image data from panel.
12. Workstation receives all image data from panel.

If Hardware Pre-offset and Hardware calibration is selected, image got is the final image.

If Hardware Post offset and Hardware calibration is selected, image got from detector would be preview image (2x2 binning). After step12, Detector would do another dark image acquisition. With both light image and dark image, detector completes all the correction process. Finally, detector uploads corrected image and workstation shows on screen.

5.5.4 Abnormal Action

Action1: after Step4, if user wants to cancel this exposure cycle, IDetector provides an "Abort Exp" function to close exposure windows. However, IDetector allows user to click "Abort Exp" until Workstation receives first image.

Action2: after Step4, if user does not shoot X-ray in exposure windows, panel would close exposure windows automatically and send a message to workstation that waiting for X-ray shooting is overtime. Meanwhile, panel would also start image acquisition. After image acquisition, panel sends image to workstation.

5.6 After use

1. Disconnect the software
2. Power off
3. Keep it clean
4. Store under specified conditions

6. Regulatory Information

6.1 <i>Medical equipment safety standards</i>	59
6.2 <i>Guidance and manufacture's declaration for EMC</i>	60
6.3 <i>Product Label</i>	63

6.1 Medical equipment safety standards

Medical equipment classification

Type of protection against electrical shock	Class I Equipment, using medical approved power supply
Degree of protection against electrical shock	B-Type applied part
Degree of protection against ingress of water	IPX1 for detector main unit
Mode of operation	Continuous operation
Flammable anesthetics	Not suitable for use in the presence of a flammable anesthetic mixture with air or with oxygen or nitrous oxide Not suitable for use in the oxygen rich environment

Note: The product safety standards that apply to Venu1717X which includes the main units: detector

References harmonized standards under Directive 93/42/EEC

MDD (93/42/EEC)	Medical Device Directive
EN ISO 13485:2012/EN ISO 13485:2012/AC:2012	Medical devices --- Quality management systems --- Requirements for regulatory purposes
EN ISO14971: 2012	Medical device – Application of risk management to medical devices
IEC 60601-1:2005+ Amendment 1:2012/EN 60601-1:2006+ Amendment 1:2013	Medical electrical equipment -- Part 1: General requirements for basic safety and essential performance
ANSI ES60601-1:2005+A1:2012	Medical electrical equipment -- Part 1: General requirements for basic safety and essential

	performance
IEC 60601-1-2:2014/EN60601-1-2:2015	Medical electrical equipment - Part 1-2: General requirements for basic safety and essential performance - Collateral Standard: Electromagnetic disturbances - Requirements and tests
IEC 60601-2-54:2009+A1:2015/EN 60601-2-54:2009+A1:2015	Medical electrical equipment -- Part 2-54: Particular requirements for the basic safety and essential performance of X-ray equipment for radiography and radioscopy
EN 62220-1:2004	Medical electrical equipment - Characteristics of digital X-ray imaging devices - Part 1: Determination of the detective quantum efficiency
EN 62304:2006/AC:2008	Medical device software - Software life-cycle processes
EN 62366:2008	Medical devices - Application of usability engineering to medical devices

6.2 Guidance and manufacture’s declaration for EMC

The compliance for each EMISSIONS and IMMUNITY standard or test specified by IEC60601-1-2 standard

EMI Compliance Table

Emission

Phenomenon	Compliance	Electromagnetic environment
RF emissions	CISPR 11 Group 1, Class B	Professional healthcare facility environment
Harmonic distortion	IEC 61000-3-2 Class A	Professional healthcare facility environment
Voltage fluctuations and flicker	IEC 61000-3-3 Compliance	Professional healthcare facility environment

EMS Compliance Table

Enclosure Port

Phenomenon	Basic EMC standard	Immunity test levels
		Professional healthcare facility environment
Electrostatic Discharge	IEC 61000-4-2	± 8 kV contact ± 2 kV, ± 4 kV, ± 8 kV, ± 15 kV air
Radiated RF EM field	IEC 61000-4-3	3V/m 80MHz-2.7GHz 80% AM at 1kHz
Proximity fields from RF wireless communications equipment	IEC 61000-4-3	Refer to table 3
Rated power frequency magnetic fields	IEC 61000-4-8	30A/m 50Hz or 60Hz

Proximity fields from RF wireless communications equipment

Test frequency (MHz)	Band (MHz)	Immunity test levels
		Professional healthcare facility environment
385	380-390	Pulse modulation 18Hz, 27V/m
450	430-470	FM, ± 5 kHz deviation, 1kHz sine, 28V/m
710	704-787	Pulse modulation 217Hz, 9V/m
745		
780		
810	800-960	Pulse modulation 18Hz, 28V/m
870		
930		
1720	1700-1990	Pulse modulation 217Hz, 28V/m
1845		
1970		
2450	2400-2570	Pulse modulation 217Hz, 28V/m
5240	5100-5800	Pulse modulation 217Hz, 9V/m
5500		
5785		

Input a.c. power Port

Phenomenon	Basic EMC	Immunity test levels
------------	-----------	----------------------

	standard	Professional healthcare facility environment
Electrical fast transients/burst	IEC 61000-4-4	±2 kV 100kHz repetition frequency
Surges Line-to-line	IEC 61000-4-5	±0.5 kV, ±1 kV
Surges Line-to-ground	IEC 61000-4-5	±0.5 kV, ±1 kV, ±2 kV
Conducted disturbances induced by RF fields	IEC 61000-4-6	3V, 0.15MHz-80MHz 6V in ISM bands between 0.15MHz and 80MHz 80%AM at 1kHz
Voltage dips	IEC 61000-4-11	0% UT; 0.5 cycle At 0°, 45°, 90°, 135°, 180°, 225°, 270° and 315°
		0% UT; 1 cycle and 70% UT; 25/30 cycles Single phase: at 0°
Voltage interruptions	IEC 61000-4-11	0% UT; 250/300 cycles

- **Cables information below is provided for EMC reference.**

Cable	Recommended cable length	Shielded or Unshielded	Number	Cable classification
AC Power Cable	1.8m	Unshielded	1 pcs	AC Power
Ethernet Cable	15m	Shielded	1 pcs	Signal
HVG Cable	15m	Shielded	1 pcs	Signal

- **Important information regarding Electro Magnetic Compatibility (EMC)**

VENU1717X require special precautions regarding EMC and needs to be installed only by iRay or authorized personnel and put into service according to EMC information provided in the user manual. VENU1717X in use may be susceptible to electromagnetic interference from portable and mobile RF communications such as mobile (cellular) telephones. Electromagnetic interference may result in incorrect operation of the system and create a potentially unsafe situation.

VENU1717X conforms to this EN60601-1-2:2014 standard for both immunity and emissions.

Nevertheless, special precautions need to be observed:

The use of accessories, transmitters and cables other than those specified by this User Manual, with the exception of accessories and cables sold by iRay of VENU1717X as replacement parts for internal components, may result in increased EMISSIONS or decreased IMMUNITY of VENU1717X.

VENU1717X should not be used adjacent to or stacked with other equipment.

6.3 Product Label



平板探测器及其影像系统

产品型号: Venu1717X
 接入电源: 控制盒供电输入 24V \equiv 1.25A
 输入功率: 50VA Max.
 电网电源输入: 220V~50HZ
 附属设备 Venu1717X GB9706.14-1997

上海奕瑞光电子科技股份有限公司
 上海市浦东新区
 瑞庆路590号9幢2层202室 20XX-XX

IPX1

20XX-XX

20XX-XX-XX

其它内容详见说明书

Flat Panel Detector

Model: Venu1717X
 Power: Adapter Port Input 24V \equiv 1.25A

iRay Technology Co., Ltd.
 Rm. 202, Building 7, No. 590, Ruiqing Rd.,
 Zhangjiang East, Pudong, Shanghai, China
 www.iraygroup.com 20XX-XX

20XX-XX

IPX1

CE

SN

7. Service Information

7.1 Product lifetime	66
7.2 Regular inspection and Maintenance	66
7.3 Repair	66

7.1 Product lifetime

The estimated product lifetime is up to 6 years under appropriate regular inspection and maintenance.

7.2 Regular inspection and Maintenance

In order to ensure the safety of patients, operating person and third parties, and to maintain the performance and reliability of the equipment, be sure to perform regular inspection at least once a year. If necessary, clean up the equipment, make adjustments, or replace consumables such as fuses, detector cable, etc. There may be cases where overhaul is recommended depending on conditions. Contact iRay service office or local iRay dealer for regular inspection or maintenance.

7.3 Repair

If a problem cannot be solved even taking the measures indicated in troubleshooting, contact your sales representative or local iRay dealer for repairs. Please refer to the name label and provide the following information:

Product Name:

Series Number:

Description of Problem: as clearly as possible.

8. Appendix

<i>Appendix A Information of Manufactures</i>	<i>68</i>
<i>Appendix B Information of Europe Representative</i>	<i>69</i>
<i>Appendix C the compatible interface circuit of the Enable_Out_P.....</i>	<i>70</i>

Appendix A Information of Manufactures



COMPANY: iRay Technology Co., Ltd.
ADDRESS: Rm. 202, Building 7, No. 590, Ruiqing Rd.,
Zhangjiang East, Pudong
ZIP CODE: 201201
TELEPHONE: +86 021-50720560
FAX: +86 021-50720561
HOMEPAGE: *WWW.IRAYGROUP.COM*
SERVICE: SERVICE DEPARTMENT OF IRAY
SERVICE TEL +86 021-50720560
MARKET TEL +86 021-50720560

Appendix B Information of Europe Representative



COMPANY: iRay Europe GmbH
ADDRESS: IN DEN DORFWIESEN 14, 71720 OBERSTENFELD
GERMANY
ZIP CODE: /
TELEPHONE: +49-7062-977 88 00
FAX: +49-7062-976 0571
HOMEPAGE: WWW.IRAYGROUP.COM
EMAIL: S.FENG@IRAYGROUP.COM

Appendix C the compatible interface circuit of the Enable_Out_P

A. Recommended Interface Circuit of the HVG

The forward direction of the optocoupler at the end of the HVG is not pulled up. The recommended interface circuit and connection mode are shown in the following figure.

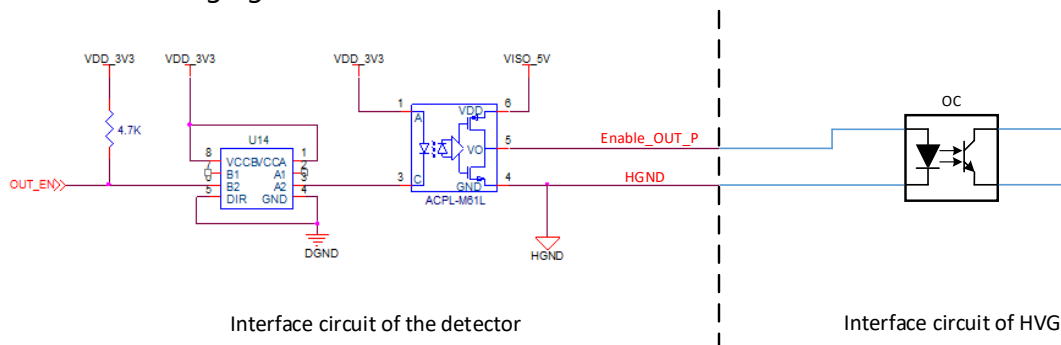

B. Compatible Interface Circuit of the HVG

In addition to the above-mentioned recommended interface circuit, it is also compatible with the following two interface circuits and connection modes.

1) The forward direction of the optocoupler at the end of the HVG has a pull-up termination.

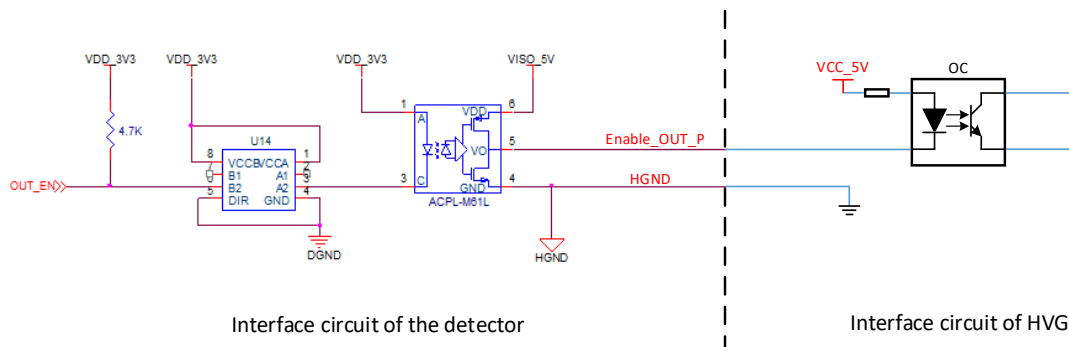

2) Operational amplifier termination mode of HVG

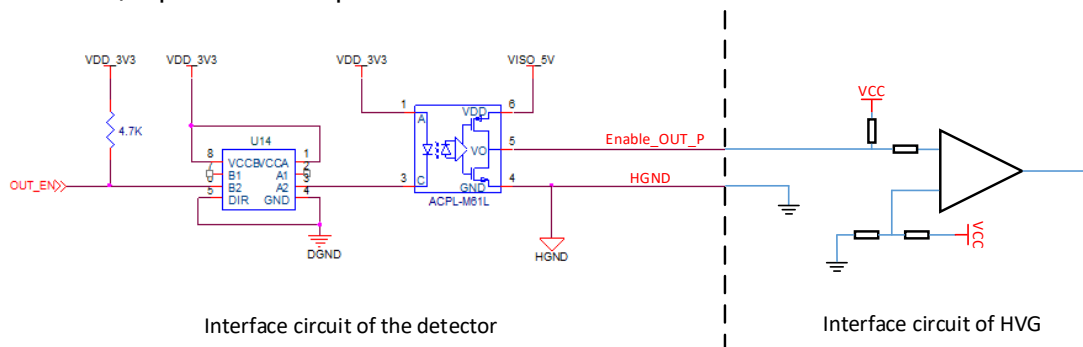

Note: VCC at HVG must be less than or equal to 10V.

3) Other HVG interface circuits not involved must be confirmed by the company's technical support personnel before connected.